



User Reference Manual
v.21

cadfocus

Introduction

GEOsCAD2 is an ad-on drafting application tools for ZWCAD and AutoCAD software with large collection of productivity CAD routines for Land Survey / Civil / Planner/.. drawings creation.

Developed base on on more than 20 years end-user industry experience, GEOsCAD2 offer automation of CAD routines drafting work while strictly adhering to industry requirements. GEOsCAD2 helps you create excellence drawing s, reduce errors, and save time.

GEOsCAD2 v.21 - Recommended System Requirements:

Operating system	Microsoft® Windows 8 /10
Processor	Intel® Core™2 Duo or AMD® Athlon™ X2 CPU or higher
RAM	Minimum 4GB , 8GB Recommended
Display card	1 GB or more
Hard disk	4 GB free space in OS disk, 2 GB free space in installation disk
Resolution	Minimum 1024 x 768 or higher
Pointing device	Mouse, trackball, or other devices
CD/DVD-ROM	Any speed (for installation only)
CAD Software	Pre install ZWCAD or AutocAD

CAD Software platform and version supported

ZWCAD	Version 2018 - 2021		
AutoCAD	Version 2018 - 2021		

Copyright © 2016 – 2021 CAD FOCUS SDN BHD

All rights reserved. This book or any portion thereof may not be reproduced or used in any manner whatsoever without the express written permission of the publisher.

GEOsCAD2 Features List v.21

GEOsCAD2 v.21 Feature List			
	GEOsCAD2 v.21 Feature List	STD	PRO
Licensing	Dongle (USB) & Permanent	✓	✓
Compatibility / Platform	ZWCAD 2018 – 2020 (Std / Pro Module)	✓	✓ (Pro)
	AutoCAD 2016 – 2020 (Applicable to GEOsCAD2 for AutoCAD Version only)	✓	✓
Bearing and Distance (Auto / Manual Labeling)	- Base on single or group selection of Lines (Entity)	✓	✓
	- Base 2-Points or Polygon (Close Boundary)	✓	✓
	- Reverse Bearing , Add Bearing Spacing..	✓	✓
Area (Calculate & Labeling)	- Automatic (Batch)	✓	✓
	- Semi-auto by selecting a Close Boundary.	✓	✓
	- By selecting multiple Points	✓	✓
	- Measurements Units (M2, Ha, Ek, Kp)	✓	✓
Table	- Bearing Distance / Coordinate Table	✓	✓
	- 2D Polyline / 3D Polyline Vertex points	✓	✓
Lot Number / Number (Labeling)	- Automatic (Batch) with User define Option	✓	✓
	- Manual (Individual)	✓	✓
	Add (PT / PTD / PTB / PLOT / A / C....) To Lot Number	✓	✓
	Add Prefix or Suffix for Number / Text	✓	✓
Road Width (Labeling)	- Vertical / Horizontal	✓	✓
	- Meter / Feet	✓	✓
Traverse Line (Functions)	- Auto Plot Boundary / Stn.No. (Bearing & Distance)	✓	✓
	- Radiate from Station	✓	✓
	- Misclose Report	✓	✓
	- Bowditch / Transit / Crandall / Po and New Adjust	✓	✓
	- Link Survey Traverse Adjust Misclose	✓	✓
Insert Symbol Tools	Boundary Marks (Trim / Without)	✓	✓
	Cutting Symbol – Civil Engineer Style (Fill / Without)	✓	✓
	Cutting Symbol – Surveyor Style (Fill / Without)	✓	✓
	Points Symbol (LP / EP / TP / MH / HWP....)	✓	✓
	Insert Stone Number	✓	✓
Plot House Corner	Plot House Corner	✓	✓
Spot Level	Change Datum (Text / Point Level)	✓	✓
	Add IL to Spot Height	✓	✓
	Auto Create Spot Level Text From XYZ Points	✓	✓
Points	Add, Interpolate, Change Datum	✓	✓
	Auto Create XYZ Points from Spot Level Text and Vice versa	✓	✓
	Label Coordinates Points	✓	✓
	Generate Points from LWPolyline	✓	✓
	Generate Points From 3D Polyline	✓	✓
Triangulation (TIN)	Generate TIN 3D Model (Line) from 3D Points	✓	✓
	Generate TIN 3D Model (3D Polygon) from 3D Points	☒	✓
Interpolation	3D Spot Level - Base on 2 Reference 3D Points	✓	✓
	Intersect 3D Points – Base on Line Drawn Across TIN 3D Model (Line)	✓	✓

Cross Section & Long Profile	Generate Cross Section from Line drawn across XYZ-points	✓	✓
	Generate Long Profile from Line drawn across XYZ-points	✓	✓
	Copy Center Line Point – Select and Create 3D Points with a single Line drawn across XYZ-points	✓	✓
Pile Survey	Set Pile Number	✓	✓
	ASCII Output for X Y / Bearing Dist X Y	✓	✓
	Pile Deviation As-built	✓	✓
Others	Polyline - Multi B-poly	✓	✓
	Line - Break Lot Lines	✓	✓
	Set All Entities / Object to Elevation = 0	✓	✓
	Offset Lot Lines	✓	✓
TEXT	Rotate Text (Align / Vertical /Horizontal)	✓	✓
	Change Text Oblique Angle	✓	✓
Unit Conversion	For Distance & Spot Levels (Feet / Meter / Link / Inches)	✓	✓
	For Point (Feet / Meter / Link)	✓	✓
	For Area (Acre / Hectare / Sq Meter / Sq Feet)	✓	✓
Transformation Coordinate	Cassini to RSO or RSO to Cassini	✓	✓
	RSO to MRT or MRT to RSO	✓	✓
Label Coordinate	Standard / Sabah / Sarawak Format	✓	✓
Topo Survey	Break line, Swap 3D Triangles, ...	☒	✓
	Generate 2D Contour Polylines & Label Contour	☒	✓
	TIN functions: Auto interpolates 3D Spot Level with equal space / distance.	☒	✓
	Volume - Calculation and Overlay	☒	✓
Road Design Tools	Auto Insert Road Design Chainage & Cross Section Line	☒	✓
Color Chart	TIN / Contour / Slope base on X/Y/Z coordinates	☒	✓

Table of Contents

Introduction	ii
GEOsCAD2 Features List v.21	iii
Table of Contents	v
Setting	9
Set Scale	9
Set Line Space	10
Set Font Height	10
Set Traverse Dist (Distance unit) Type	10
Function 1: Bearing Distance	11
1.1 Brg Dist Line	11
1.2 Brg Dist with Break Line	12
1.3 Brg Dist Point 2 Point	13
1.4 Brg Dist Polygon	13
1.5 Brg Dist Setting.....	14
1.6 Reverse Brg	14
1.7 Add Brg Spacing	15
Function 2: Area	16
2.1 Area Manual.....	16
2.2 Area Auto	18
2.3 Area by Point.....	19
2.4 Area Setting (Set M2, Ha, Ek , Kp)	20
Function 3: Coordinate	21
3.1 Display Coordinate	21
3.2 Set Coordinate Precision	22
Function 4: Rotate Text (Alignment, Horizontal, Vertical)	23
Function 5: Multi B - Poly	24
Function 6: Break Lot Line	25
Function 7: Match Text Height	26
Function 8: Match Property	27
Function 9: Set All Entities Elevation to Zero	28
Function 10: Offset	29
10.1 Offset Lots	29

10.2 Offset Text.....	30
Function 11: Insert Boundary Marks Symbols	31
Function 12: Traverse Line	32
Function 13: Radiate Line from Station	33
Function 14: Traverse Line Function	34
14.1 Traverse Misclose Report.....	34
14.2 Bowditch Adjust Misclose	34
14.3 Transit Rule Adjust Misclose	35
14.4 Crandall Adjust Misclose	35
14.5 Link Survey Traverse Adjust Misclose	36
14.6 Po and New Adjust.....	36
GEOCAD2 ENGINEERING.....	39
Function 15: Plot Cutting.....	40
15.1 Plot Cutting Civil Engineer’s Symbol	40
15.2 Plot Cutting Surveyor’s Symbol.....	41
Function 16: Offset Lots Digitizing	42
Function 17: Pile Survey	43
17.1 Set Pile Number	43
17.2 ASCII Output for X Y	44
17.3 ASCII Output for Brg Dist X Y.....	45
17.4 Pile Deviation Asbuilt	46
Function 18: Set UCS	47
18.1 Set UCS to World coordinate system.....	47
Function 19: Lot Numbering	48
19.1 Lot Numbering Auto.....	48
19.2 Lot Numbering Auto – User Define (v.18.6).....	49
19.3 Lot Numbering Manual	49
Function 20: Label Spot Height with IL	51
20. Label Spot Height wit IL	51
Function 21: Label Lot Number with PT / PTD / PTB.....	52
21. Label Lot Number.....	52
Function 21: Label Prefix or Suffix for Text	53
21-1. Label Lot No with Prefix or Suffix (v.19).....	53
21-2. Label Prefix or Suffix with existing Lot No (v.19)	54
Function 22: Label Road Width.....	55

22.1 Label Road with Vertical.....	55
22.2 Label Road with Horizontal.....	55
Function 23: Table (Area & Bering Distance).....	56
23.(a) Area Table.....	56
23.(b) Shortline Brg Dist Table (v.18.6).....	57
23.(c) Polygon Brg Dist Table (v.18.6).....	58
Function 23-1 : Table (Vertex / 3D Polyline Coordinates)	59
23.1.(a) Coordinate Table for Vertex	59
23.1.(b) Coordinate Table for 3D PolyLine (v.19).....	60
Function 24: Spot Level (Text & Points).....	61
24.1 Add New Spot Level	61
24.2 Add New Point Using Spot Level (v18.6).....	62
24.3 Move 3D Point and Maintain Z value (v.19)	62
24.4 Display Height Using Spot Level (v.18.6).....	63
Function 25: Change Text Oblique Angle	64
Function 25-1 : LWPolyline , 3D-Polyline, Line Across Polyline with points.	65
25.1.(a) Add Points LWPolyline (v.19).....	65
25.1.(b) Add Points 3D Polyline (v.19)	65
25.1.(c) Add Points 3D Polyline (v.19).....	66
Function 26: Interpolation (Spot Level, Cross Section & 3D Model)	67
26.1 Interpolate Spot Level.....	67
26.2 Interpolate Cross Section.....	68
26.3.(a) TIN Model 3D Line (v.18.6)	69
26.3.(b) TIN Model 3D Polygon (v.19 Pro)	70
26.4 Interpolate Spot Level 3D Model (v.18.6).....	71
Function 27: Cross Section / Long Profile / Copy CenterLine Points	72
27.1 (a) Cross Section – X-Section Text Rotate 180Deg – Datum Auto (Updated v.21)	72
27.1(b) Cross Section : X-Section Text Rotate 180Deg -Datum Manual (Updated v.21)	74
27.2 Long Profile – Long Profile Text Rotate Angle 180Deg (Updated v.21)	76
27.3 Create Horizontal Line Points From Road/River Alignment (Updated v.21).....	77
Function 28: Text In box.....	78
Function 29: Insert Stone Number.....	79
Function 30: Pelan Lakar	80
Function 31: Change Datum for Spot Level	81
31.1 Change Datum for Text Level.....	81

31.2 Change Datum for Point Level	82
Function 32: Change Z Coord = Spot level	83
Function 33: Conversion.....	84
33.1 Unit Conversion for Distance or Levels.....	84
33.2 Unit Conversion for Points Level.....	84
33.3 Area Conversion.....	85
Function 34: AutoCad Text Output to Ascii File	86
Function 35: Point Import Ascii x y z	87
Function 36: Point Export Ascii x y z	88
Function 37: Point Symbol	89
Function 38: Transformation of Coordinate.....	91
38.1 Cassini to RSO.....	91
38.2 RSO to Cassini.....	91
38.3 RSO to MRT	91
38.4 MRT to RSO	91

Setting

To Load **GEOsCAD2** and **GEOsCAD2 Engineering** Functions. (Refer *Figure 1*)

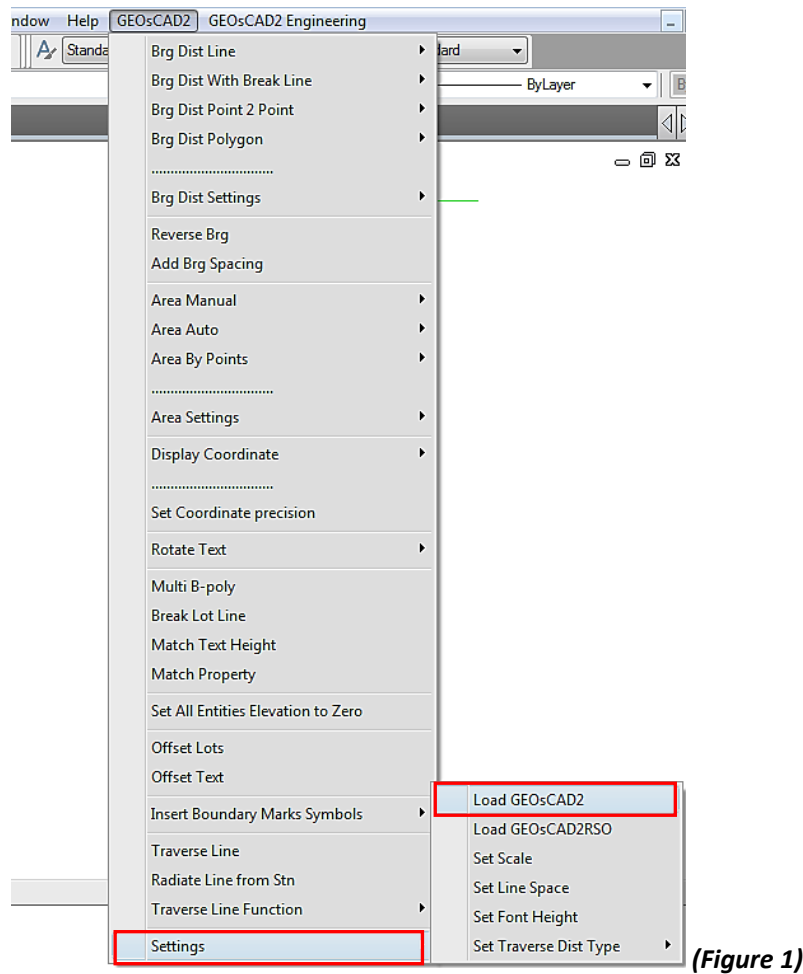

1. From the menu bar, choose GEOsCAD2 [**Settings**] → **Load GEOsCAD2**.

A successful loading will display the below message in the command prompt area.

```
Copyright (c) September 2016 Cad Focus Pte. Ltd. All Rights Reserved. GEOsCAD2 v.18.60
Command: |
714.0361, 480.3416, 0.0000
```

Note: Require to load GEOsCAD2 each time after start or opening a drawing.

Set Scale

1. From the GEOsCAD2 menu bar, choose [**Settings**] → **Set Scale**. (Refer *Figure 1*)
2. Enter text output scale :

```
Command: (C:td_setscale)
*Cancel*
Command:
Command:
Please enter new scale value <1000.0000> :
```

Set Line Space

1. From GEOsCAD2 drop-down menu, choose **[Setting]**.
2. Choose **[Set Line Space]**
3. On the Command line, enter the new value of line spacing or press Enter to accept the current default.

Please enter new default line spacing value <1> :

Set Font Height

1. From the GEOsCAD2 menu, choose **[Settings]**.
2. Choose **[Set Font Height]**.
3. On the command line, enter the font height for a new default value and then press Enter.

Please enter new default font-height value <1.6> :

Set Traverse Dist (Distance unit) Type

1. From the GEOsCAD2 menu, choose **[Settings]**.
2. Choose **[Set Traverse Dist Type]**.
3. Select prefer Distance unit. Default is in Meter

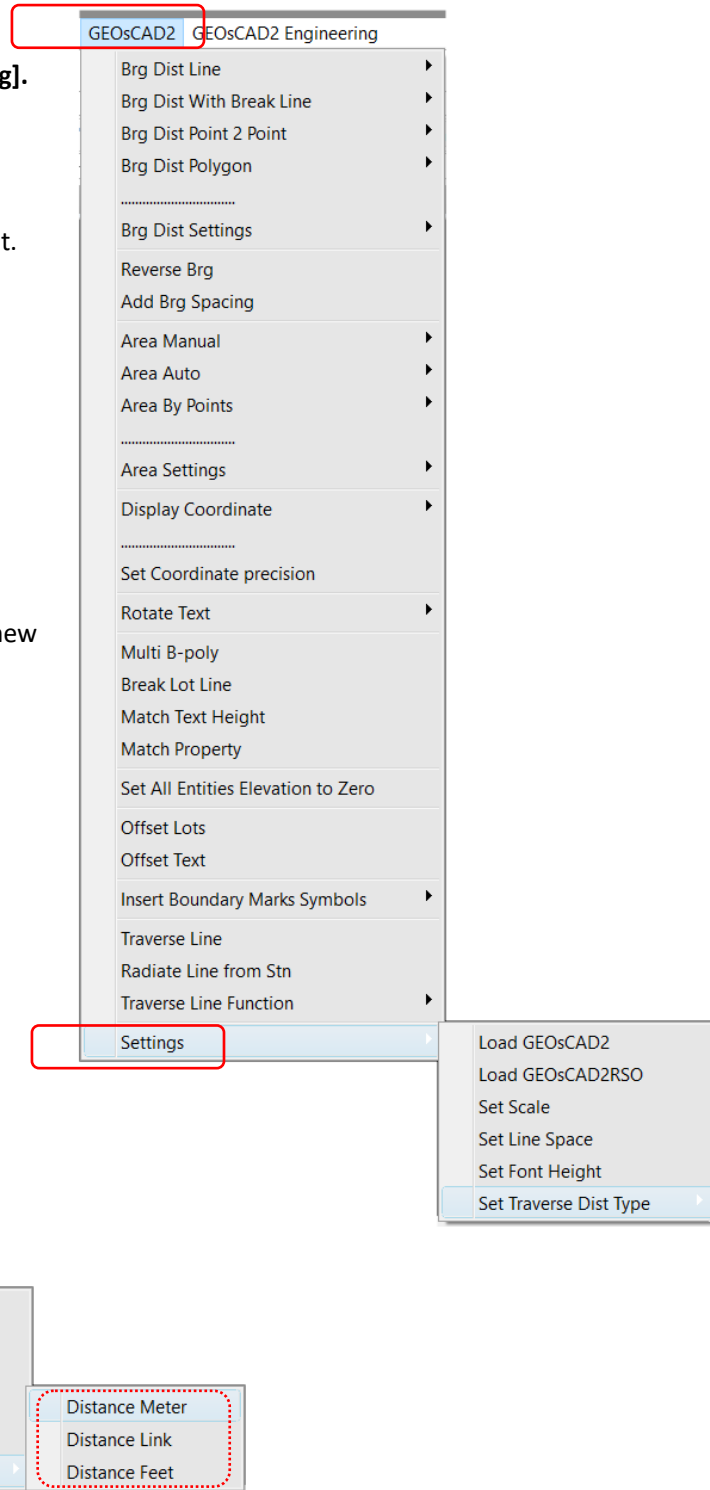

Function 1: Bearing Distance

Function Description: To show all the bearing and distance for selected object.

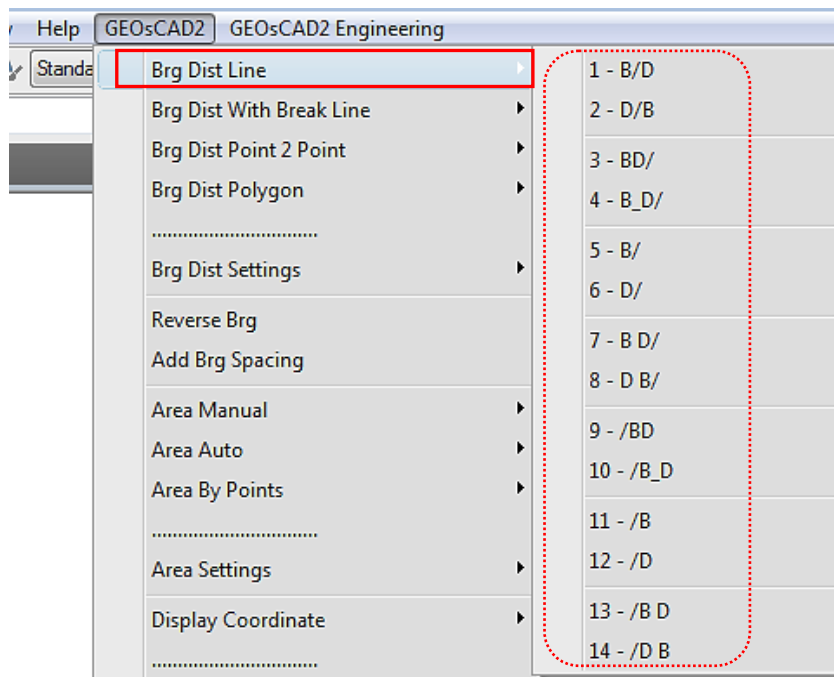

(Figure 1.1)

1.1 Brg Dist Line

1. From the GeoSCAD2 menu, choose **[Brg Dist Line]**. (Refer *Figure 1.1*)
2. Then choose the label template style from **[Brg Dist Line]** sub menu (see illustration below). Refer table below for the Bering Distance label template style.

Function	Label Style
1 - B/D	<u>Bearing</u> Distance
2- D/B	<u>Distance</u> Bearing
3 - BD/	<u>BearingDistance</u>
4 - B_D/	<u>Bearing Distance</u>
5 - B/	<u>Bearing</u>
6 - D/	<u>Distance</u>
7 - B D/	<u>Bearing</u> Distance

Function	Label Style
8 - D B/	Distance <u>Bearing</u>
9 - /BD	<u>BearingDistance</u>
10 - /B_D	<u>Bearing Distance</u>
11 - /B	<u>Bearing</u>
12 - /D	<u>Distance</u>
13 - /B	<u>Bearing</u> Distance
14 - /D B	Distance <u>Bearing</u>

1.3 Brg Dist Point 2 Point

Function Description: To show the bearing and distance by pointing the start and end point of line.

1. From the GEOCAD2 menu, choose **[Brg Dist Point 2 Point]**. (Refer *Figure 1.1*)
2. Choose the style from **[Brg Dist Polygon]** sub menu and then click the style to choose it
3. Picking start point at path, then pick end point at the line. After that click 'enter '.

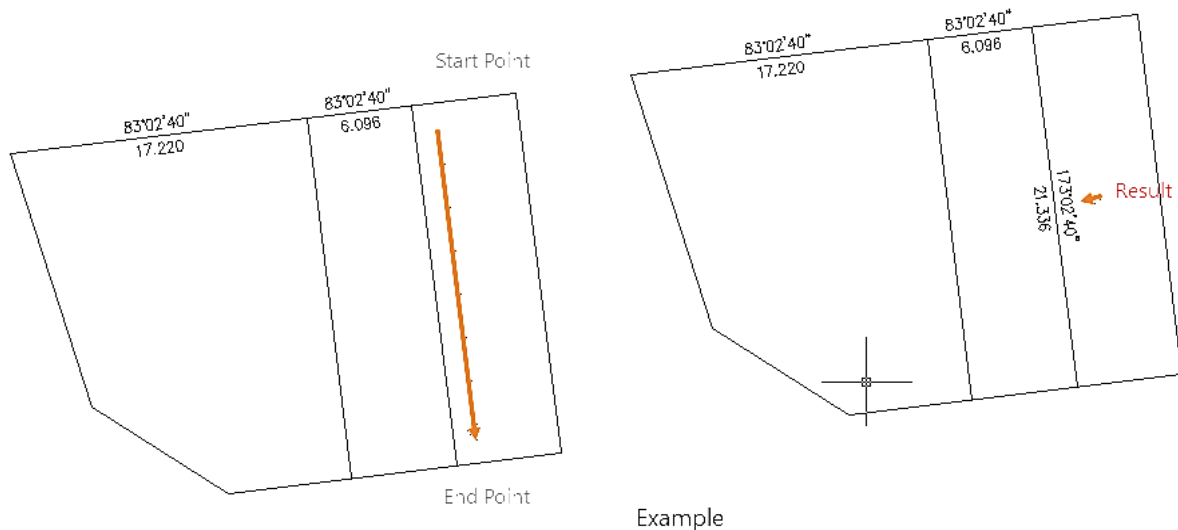

1.4 Brg Dist Polygon

Function Description: To show the bearing and distance by pick a point inside the polygon.

1. From the GEOCAD2 menu, choose **[Brg Dist Polygon]**. (Refer *Figure 1.1*)
2. Choose the style from **[Brg Dist Polygon]** sub menu and then click the style to choose it
3. Pick a point inside the polygon

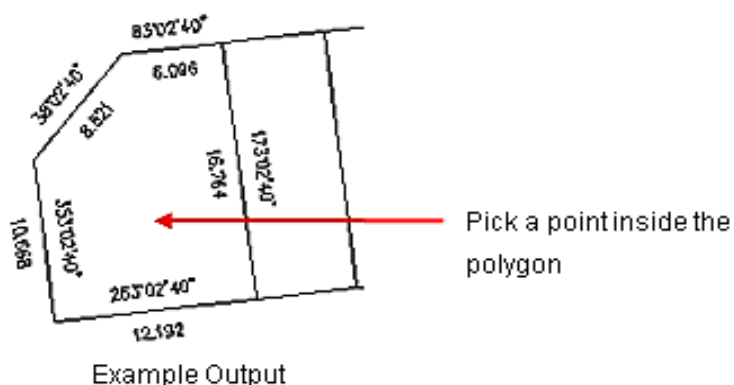

4. Repeat step 3 to continue.
5. Press Esc button or right click mouse button to deactivate the function.

1.5 Brg Dist Setting

Function Description: To set bearing distance accuracy.

1. From the GEOsCAD2 menu, choose [**Brg Dist Settings**]. (Refer *Figure 1.2*)

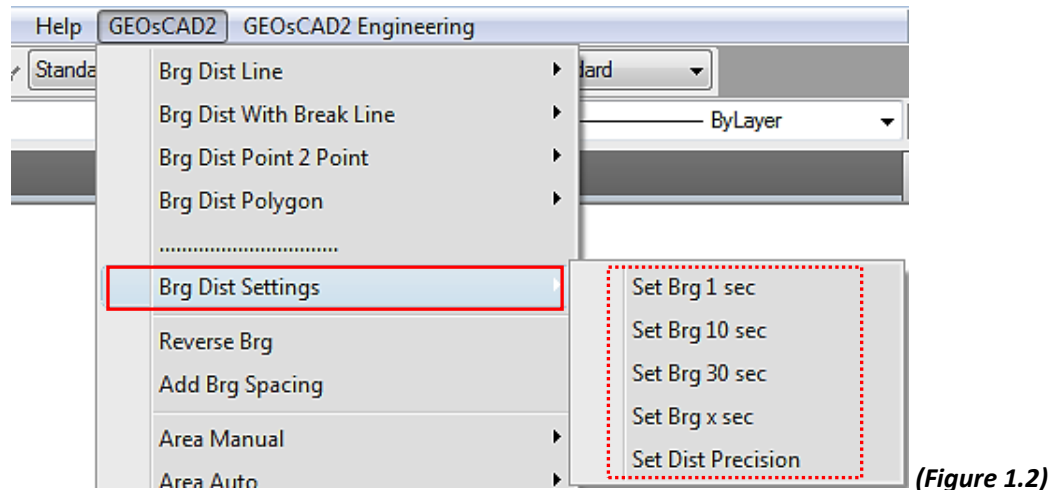

2. Choose the set bearing from [Brg Dist Settings] sub menu and click the setting selection

- Set Brg 1 sec: Precomp bearing accuracy is 1 second
- Set Brg 10 sec: Precomp bearing accuracy is 10 second
- Set Brg 30 sec: Precomp bearing accuracy is 30 second
- Set Brg x sec: Precomp bearing accuracy is x second (enter the x value and press Enter)
- Set Dist Precision: To set the new distance precision (enter the new distance value and press **Enter**).

1.6 Reverse Brg

Function Description: To reverse an existing bearing by selection

1. From GEOsCAD2 Menu, choose [**Reverse Brg**]. (Refer *Figure 1.3*)

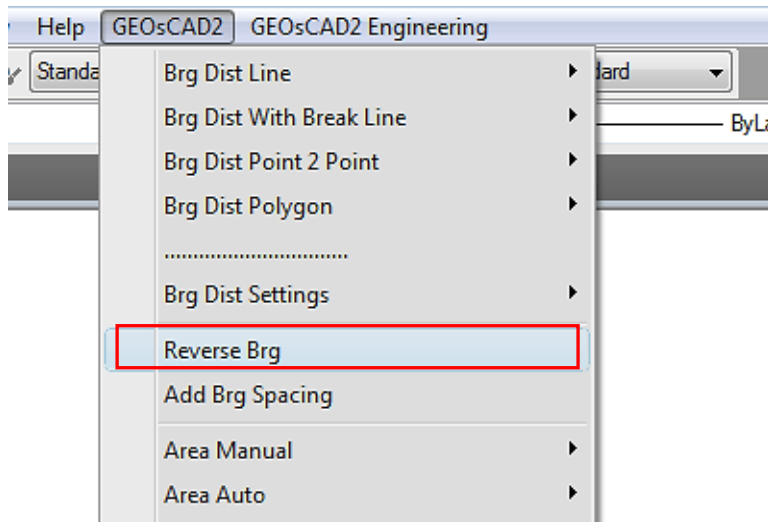

(Figure 1.3)

2. Select bearing to reverse and then right click mouse button (the bearing automatically reverse)

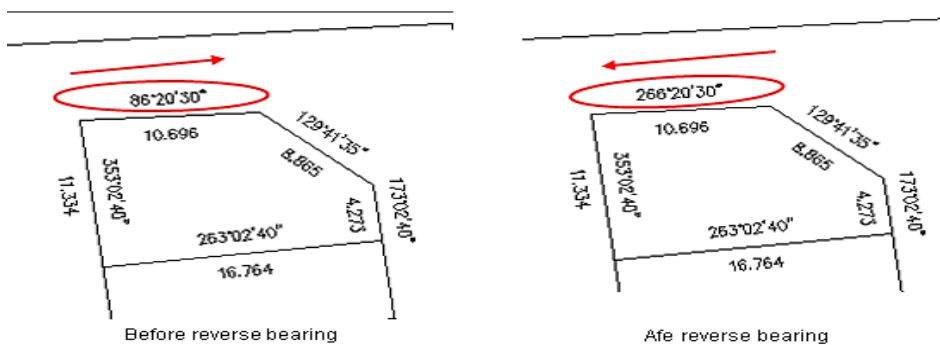

3. Repeat step 2 to reverse another bearing.

4. Press Esc button or right click mouse button to deactivate the function.

1.7 Add Brg Spacing

Function Description: To add an existing bearing spacing

1. From the GEOsCAD2 menu, choose [Add Brg Spacing]. (Refer Figure 1.4)

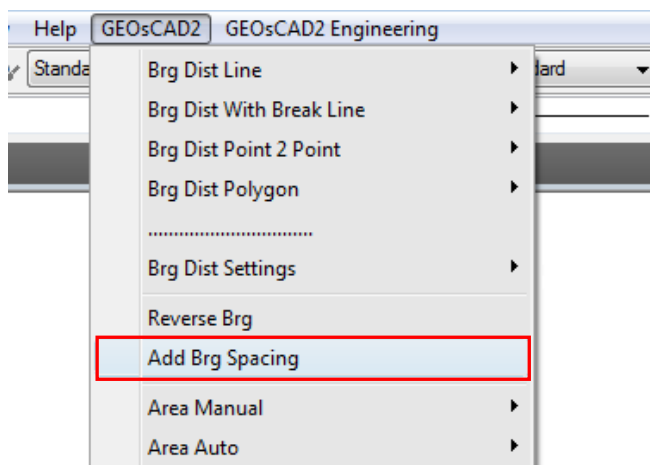

(Figure 1.4)

2. Select objects and then right click mouse button.
(Note: you can select more than one)

3. Enter the number of spacing and press [Enter].

```
Select objects: 1 found
Select objects:
+ NUMBER FOR MORE SPACE OR - NUMBER FOR LESS SPACE:
```

To increase spacing

To reduce spacing

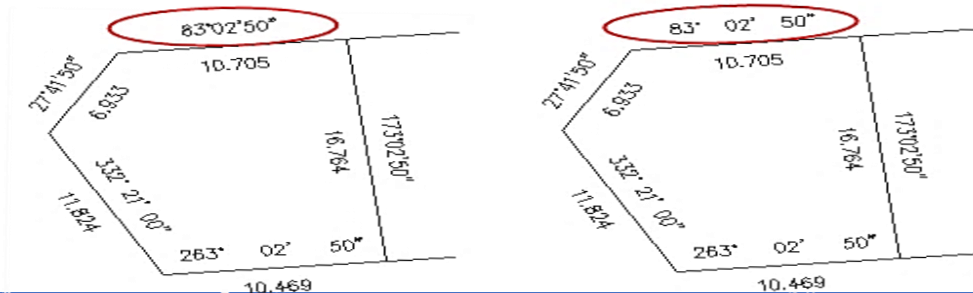

Function 2: Area

2.1 Area Manual

Function Description: To display the area of closed polygon with the selected units by click the area one by one

1. From the GEOsCAD2 menu, choose **Area manual** and area unit from **[Area manual]** sub menu. Then click selected area unit. (Refer *Figure 2.1*)

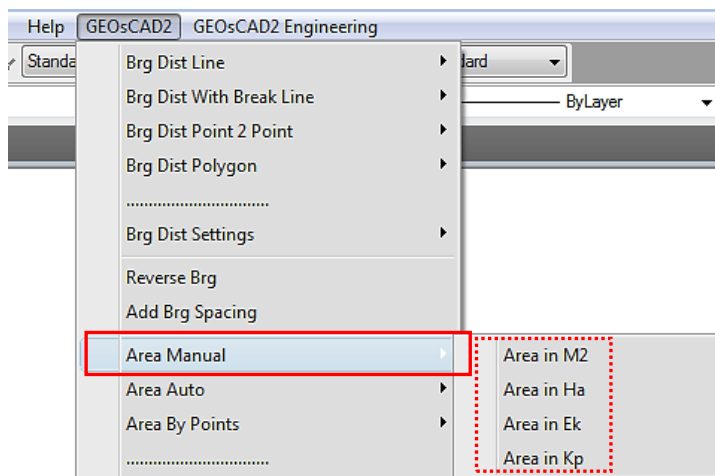

(Figure 2.1)

2. The command window will display a display format and prompt you to confirm boundary selection:

```
Command:
Display format [ m2 | Ha | Ek | Kp ] <m2>: 1
Ask to confirm boundary selection? [ y | n ] <y>
```

If the user choose area unit in meter square

Current value

3. Under *Ask to confirm boundary selection*, type “y” if you confirm the boundary selection and

type "n" if you not confirm the boundary selection then press **[Enter]**

```
Command:
Display format [ m2 | Ha | Ek | Kp ] <m2>: 1
Ask to confirm boundary selection? [ y | n ] <n>: y
Please select a line to align text to <172.4d>:
```

4. The window command will prompt you to select a line to align text.
Select a line (see example below)

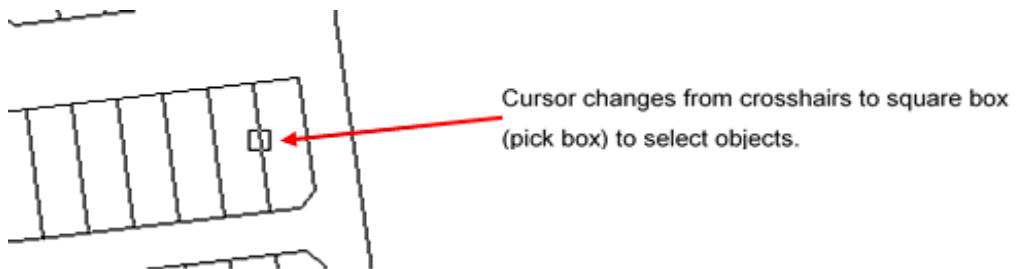

5. The current text alignment angle will display automatically in your window command and at the same time ask the user to select an area.

```
Ask to confirm boundary selection? [ y | n ] <y>:
Please select a line to align text to <83.0d>:
Current text alignment angle: 173.0d
Please select an area or cancel:
```

6. Select the area by clicking inside the polygon. At the *Is the area selected correct?* [Y| n] <y>: prompt type "y" or "n" and then press **[Enter]**.

- "y" (yes) - if the area selected is correct
- "n" (no) - if you not sure the area

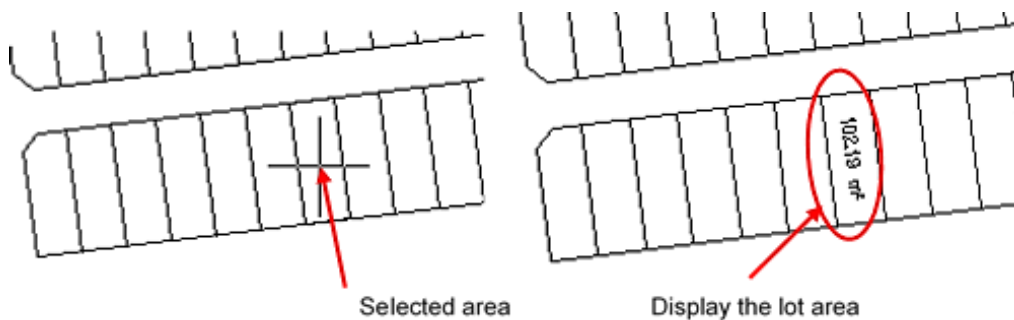

7. Repeat steps 4 to 6 to continue or press ESC to cancel the command.

2.2 Area Auto

Function Description: To display the area of closed polygon automatically

1. From the GEOsCAD2 menu, choose **[Area Auto]** → **[Midpoint or Centroid]** → **Area in M2**.
(Refer Figure 2.2)

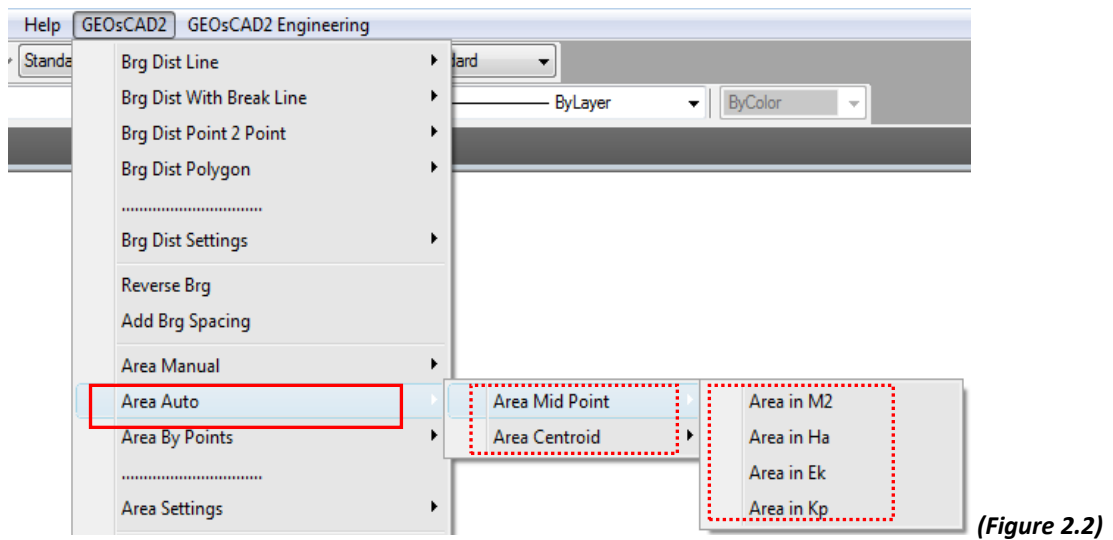

2. Ask to confirm boundary selection? [y | n] <current>: **N** and press [Enter]
3. Please select a line to align text. Select line object **(Refer to below illustration 3.)**
4. Pick a starting and end point. **(Refer to below illustration 4.)**

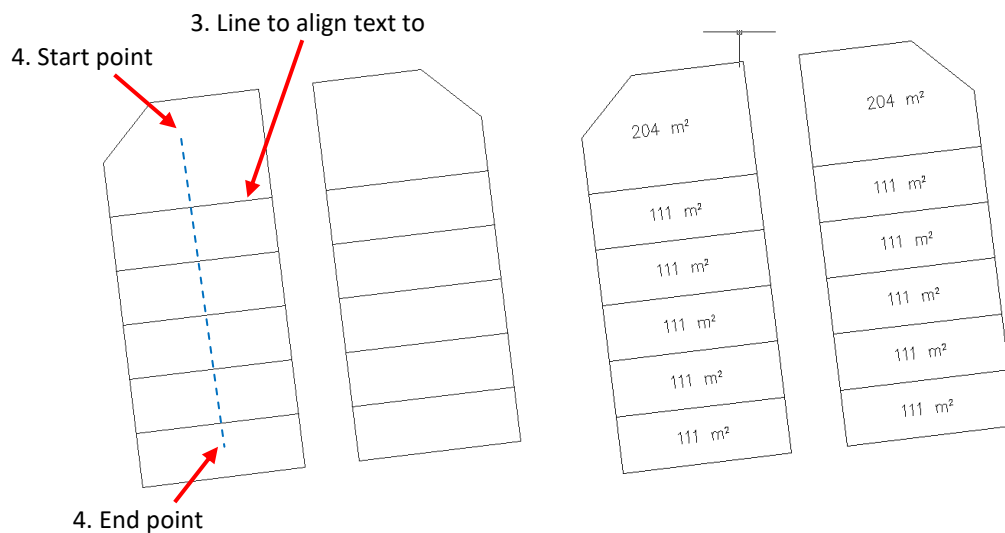

5. Repeat Step 3. & 4 to continue on other Polygon or Esc to exit.

2.3 Area by Point

Function Description: To display the area of polygon by picking points

1. From the GEOsCAD2 menu, choose **[Area by points] → Area in M2** . (Refer *Figure 2.3*)

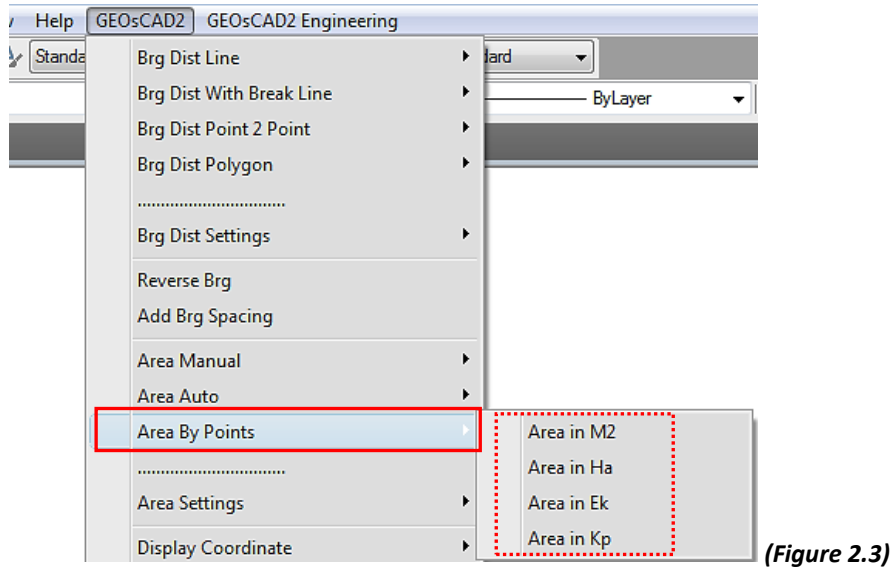

2. Please select a line to align text to <90d>: Select a line object (Refer to below illustration 2.)
3. Please select a point or cancel: Click endpoint of **a, b, c, d, e, a** and **enter** (refer to below Figure 2.3a)
4. Please select a display point or cancel: (Refer to illustration 4.)
5. Press Esc to deactivate the function.

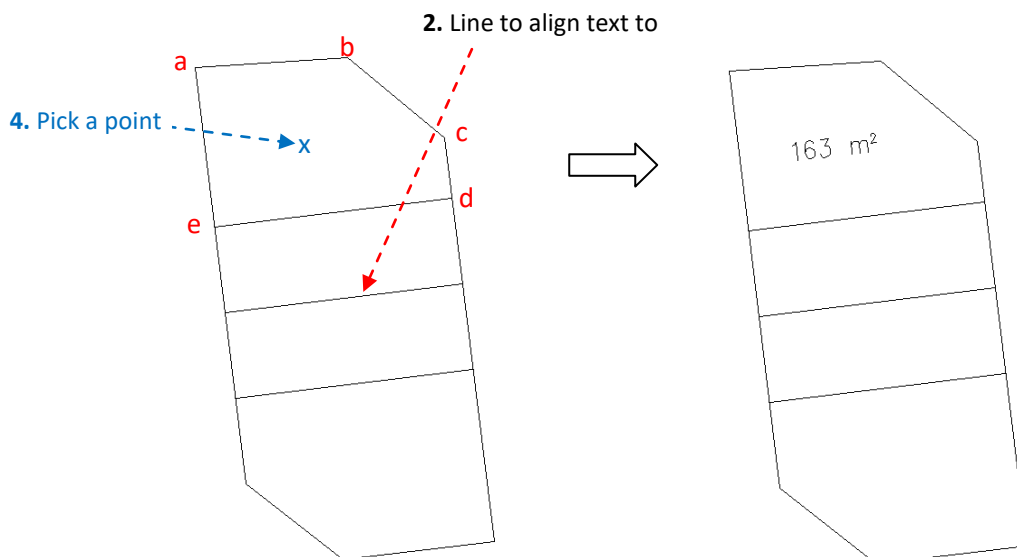

(Figure 2.3a)

2.4 Area Setting (Set M2, Ha, Ek , Kp)

Function Description: To setup area decimal places.

1. From the GEOsCAD2 menu, choose **[Area Settings]** and Set unit precision from **[Area Settings]** sub menu. Then click selected Set unit precision. **(Refer Figure 2.4)**

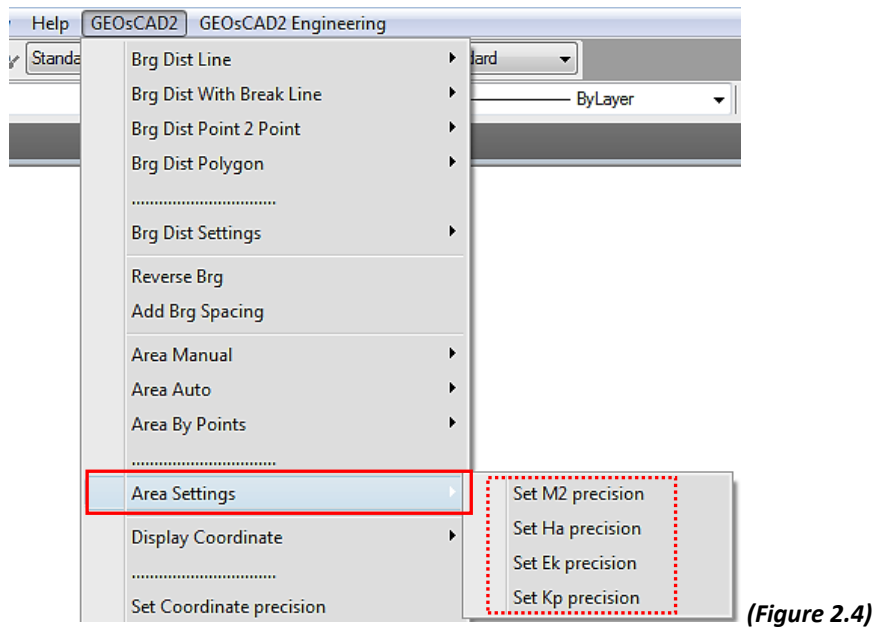

2. The command window will prompt you to enter the new unit precision value.

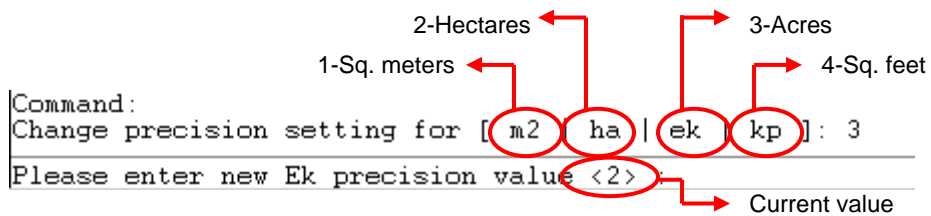

3. Enter the new value or press enter to accept the default value.

Function 3: Coordinate

3.1 Display Coordinate

Function Description: To display the coordinate

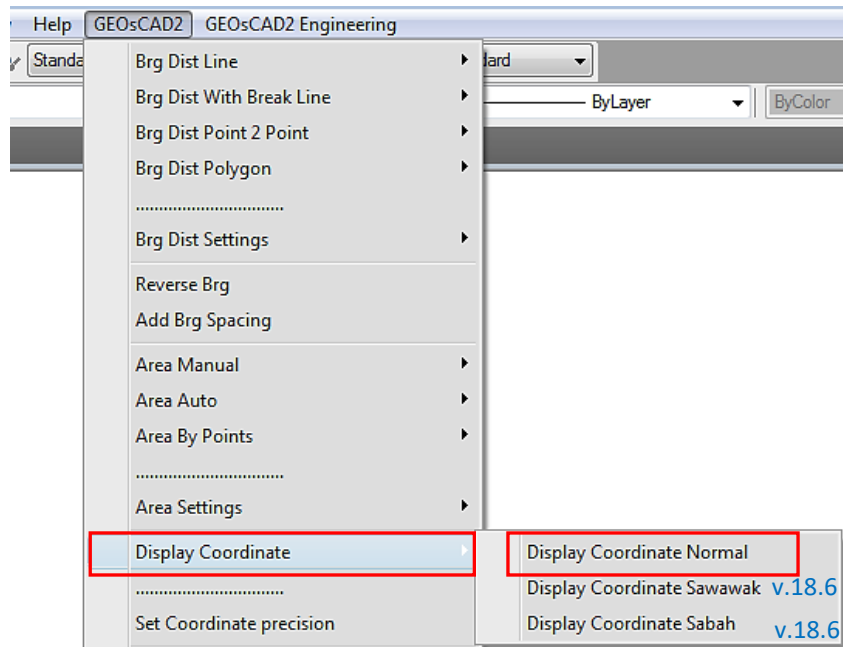

1. From the GeoSCAD2 menu, Select **[Display Coordinate]** ➤ any of the following Display format
Display Coordinate Normal
Display Coordinate Sarawak (v.18.6)
Display Coordinate Sabah (v.18.6)
2. Please select a point or cancel:
3. Please select a display point or cancel:.
4. Repeat steps 2 to 3 to continue or press Esc to cancel.

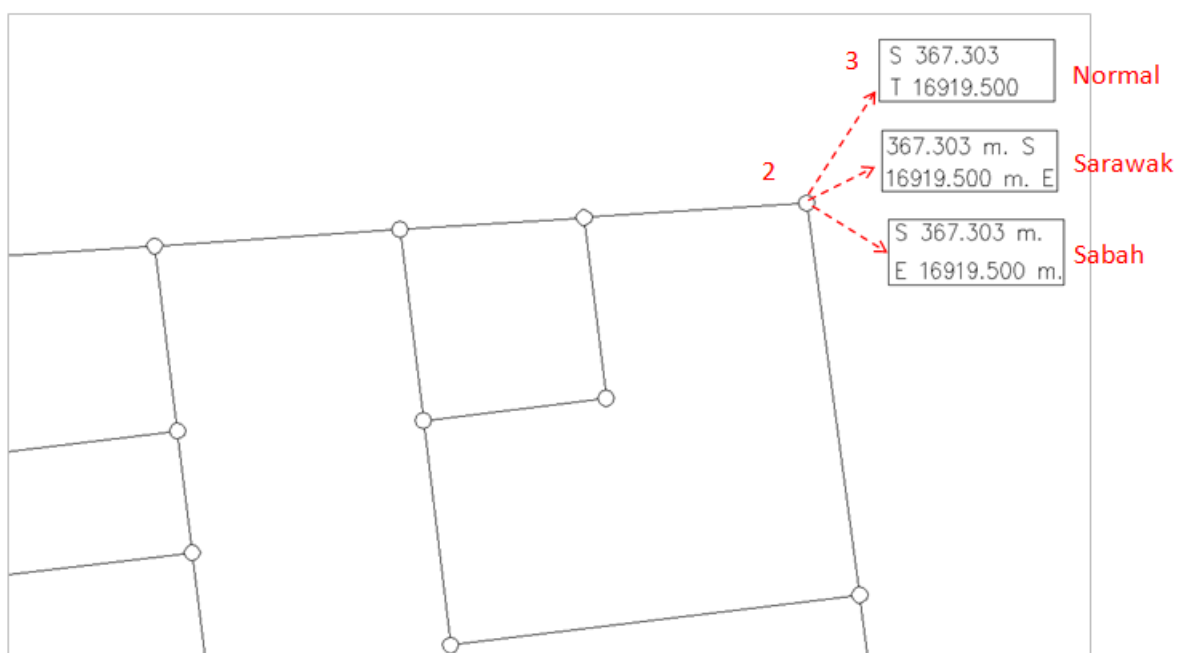

3.2 Set Coordinate Precision

Function Description: To setup coordinate decimal places.

1. From the GeoSCAD2 menu, choose **[Set Coordinate Precision]**. (Refer *Figure 3.2*)

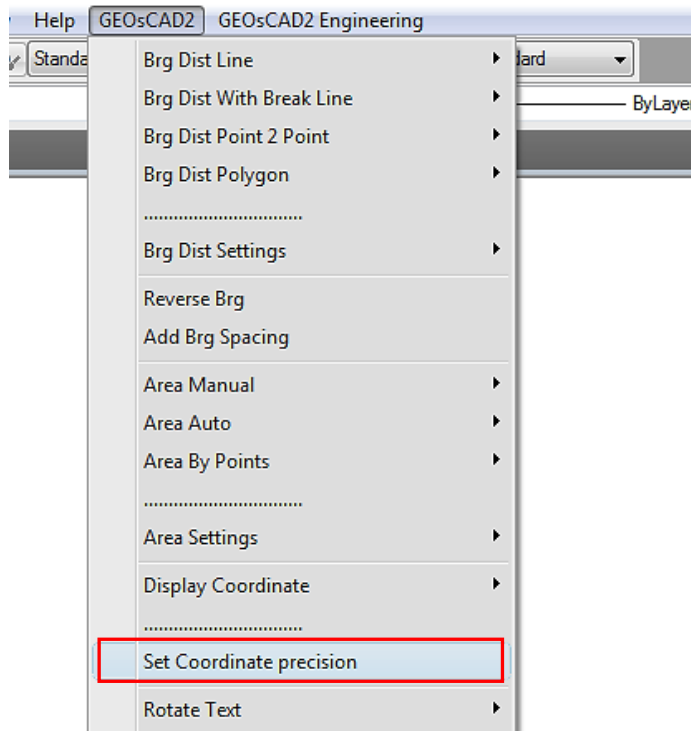

(Figure 3.2)

2. Please enter new coordinate precision value <3> : **3**

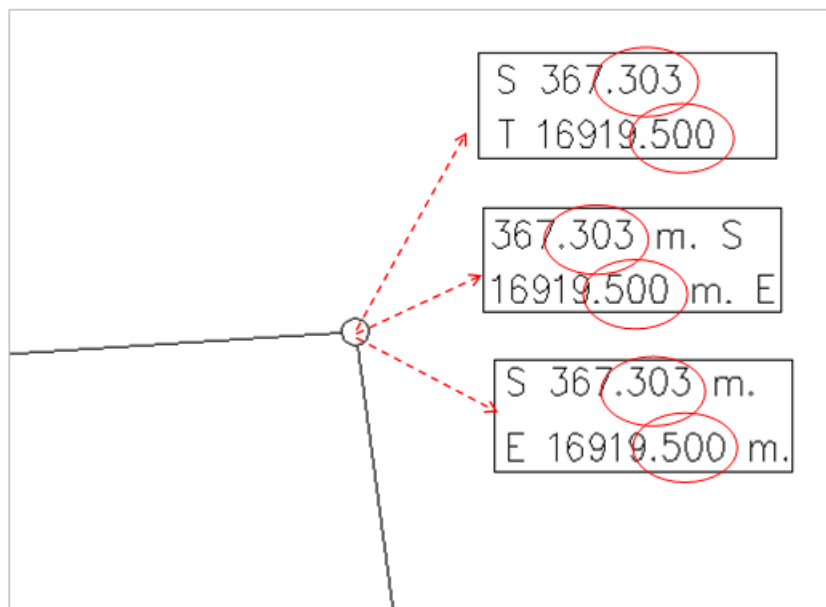

Function 4: Rotate Text (Alignment, Horizontal, Vertical)

Function Description: To rotate the text

1. From the GeoSCAD2 menu, choose **[Rotate Text]** and a rotation type from **[Rotate Text]** sub menu. **(Refer Figure 4.1)**

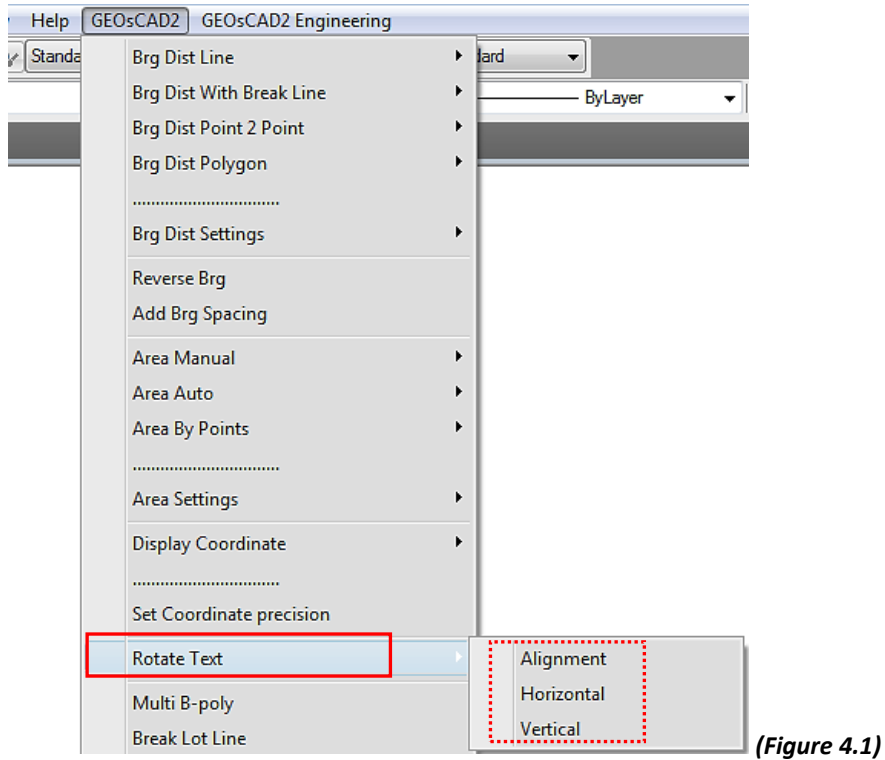

2. Select Text objects follow by enter
3. Select object for base angle (refer to below illustrations).

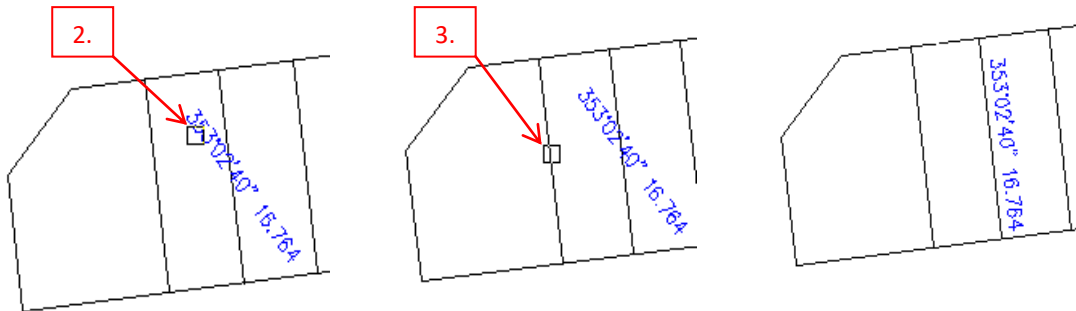

Note: The above example result is base on Rotate Text ➤ Alignment

4. Specify base point (eg. Click on Lower Left of Text) follow by displacement point (Click on to desire location).

Function 5: Multi B - Poly

Function Description: To create multi region or polyline from an enclosed area.

1. From the GeoSCAD2 menu, choose **[Multi B-Poly]**. (Refer *Figure 5.1*)

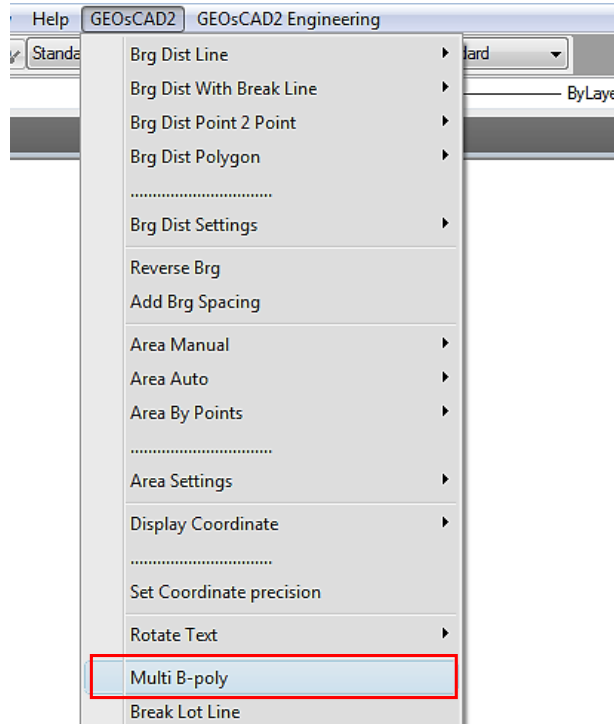

(Figure 5.1)

2. Select objects (Lines) and then press Enter.

Note: Multi B-Poly function only works when there is Lot number inside the boundary.

3. Example Final result:

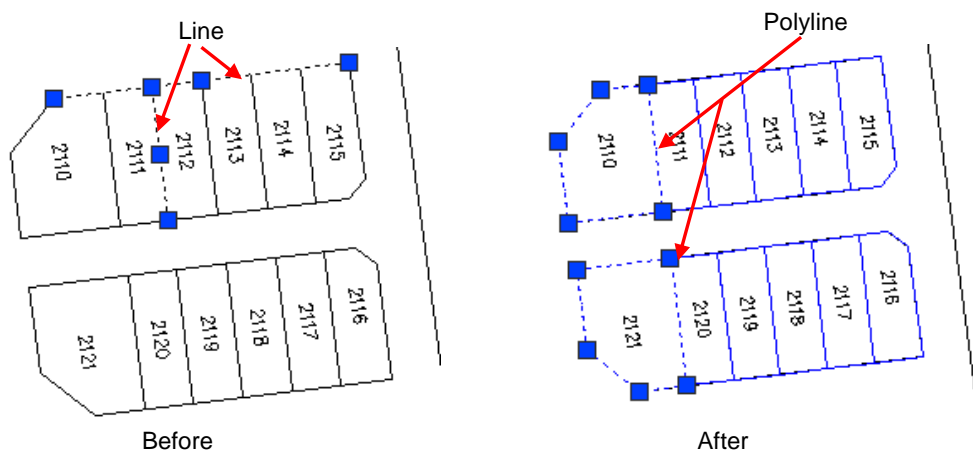

Function 6: Break Lot Line

Function Description: To break any lines or polyline intersects.

1. From GeoSCAD2 menu, select **[Break Lot Line]**. (Refer *Figure 6.1*)

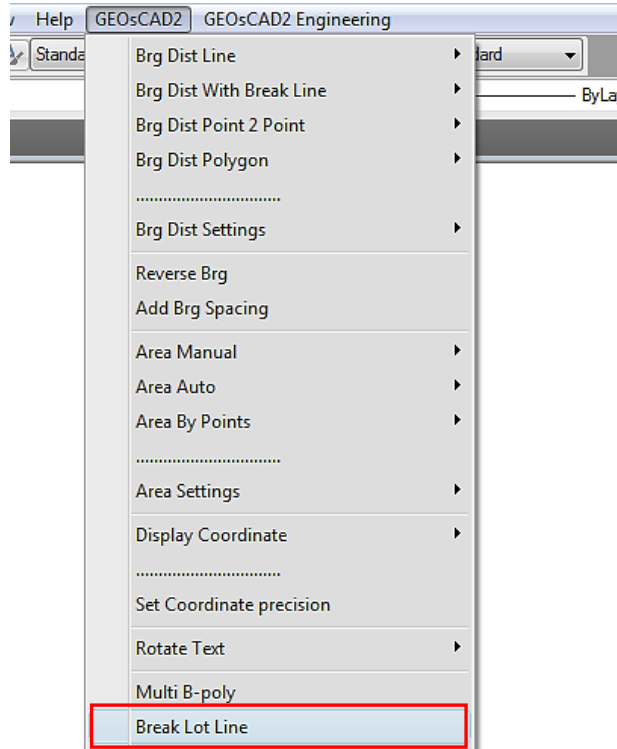

(Figure 6.1)

2. Select objects follow by enter or right click mouse button
3. Repeat step 2 to continue or press Esc to cancel.
4. Example:

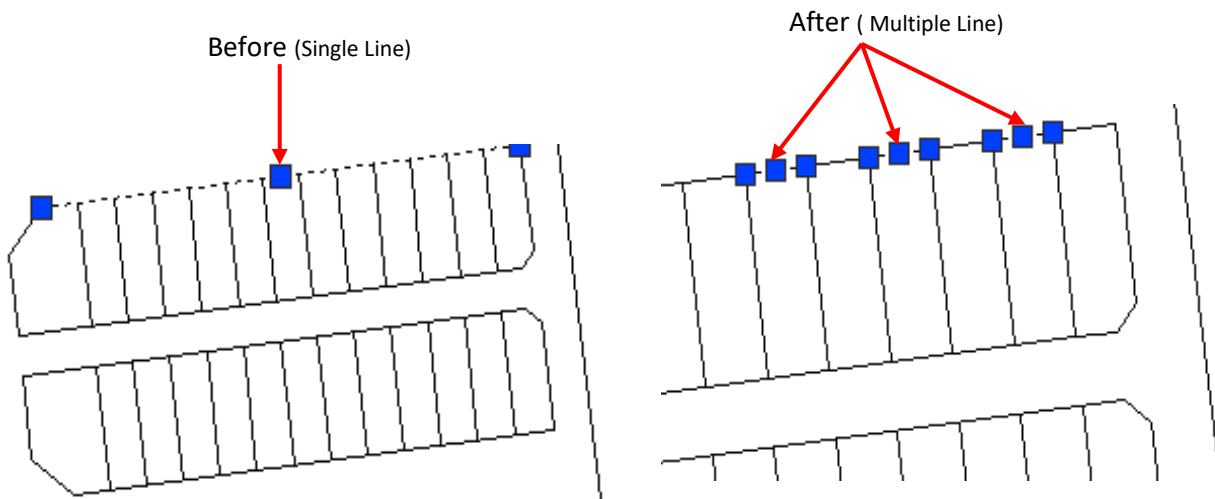

Note: New objects will be created overlay above the original object.

Function 7: Match Text Height

Function Description: To copy a text height from selected text by selecting the text destination and then select the text source.

1. From the GeoSCAD2 menu, choose **[Match Text Height]**. (Refer *Figure 7.1*)

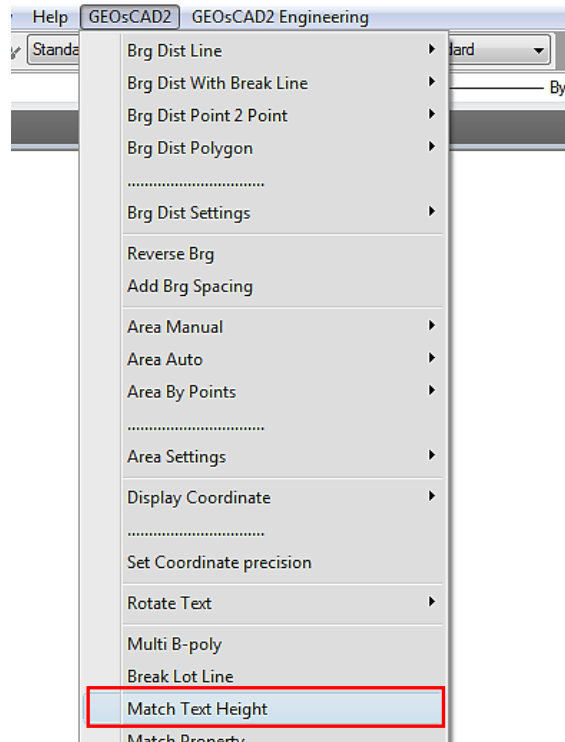

(Figure 7.1)

2. Select text that you want to change the text height and then right click mouse button.
3. The window command will prompt you to select text entity height to match, select the source text.
(See figure below to understand the procedure)

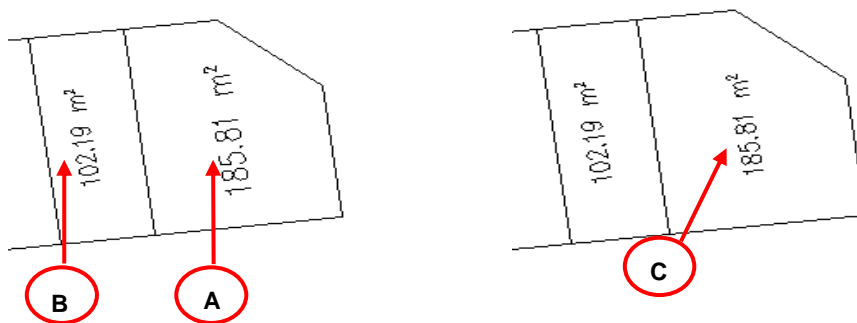

Example: Select **A** (destination) and then select **B** (source). The result is **C** (**A** will take a **B** text height)

4. Repeat the steps 2 and 3 to continue or press Esc to cancel.

Function 8: Match Property

Function Description: To copy some or all properties of one object to other object. The types of properties that can be copied include color, layer, linetype, linetype scale, line weight, plot style, and thickness.

1. From the GeoSCAD2 menu, choose **[Match Property]**. (Refer *Figure 8.1*)

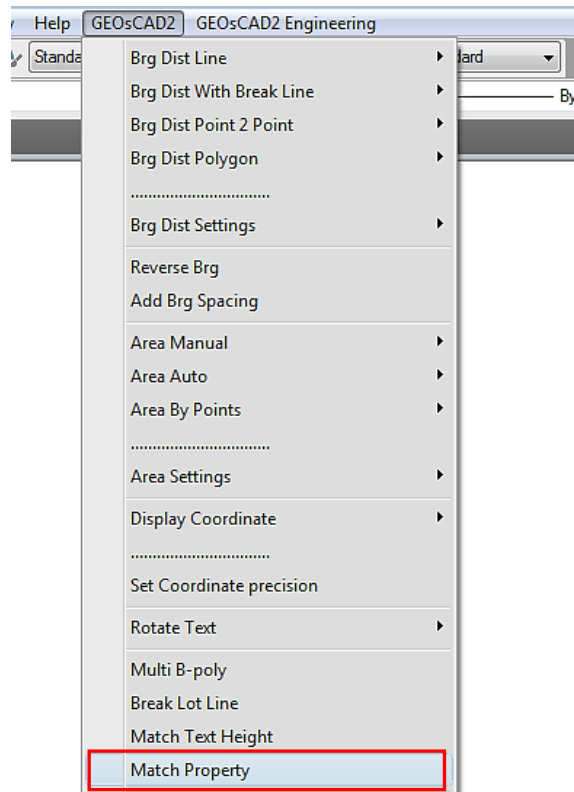

(Figure 8.1)

2. Select the object whose properties you want to copy.
3. If you want to control which properties are transferred, enter 'S' (Settings). In the 'Property Settings' dialog box, clear the items that you do not want copied (all are on by default). Click 'OK'.
4. Select the objects to which to apply the selected properties and press ENTER.

Function 9: Set All Entities Elevation to Zero

Function Description: To set the Z value to zero (to convert 3D polyline to 2D polyline)

1. From the GeoSCAD2 menu, choose **[Set All Entities Elevation to Zero]**. (Refer *Figure 9.1*)

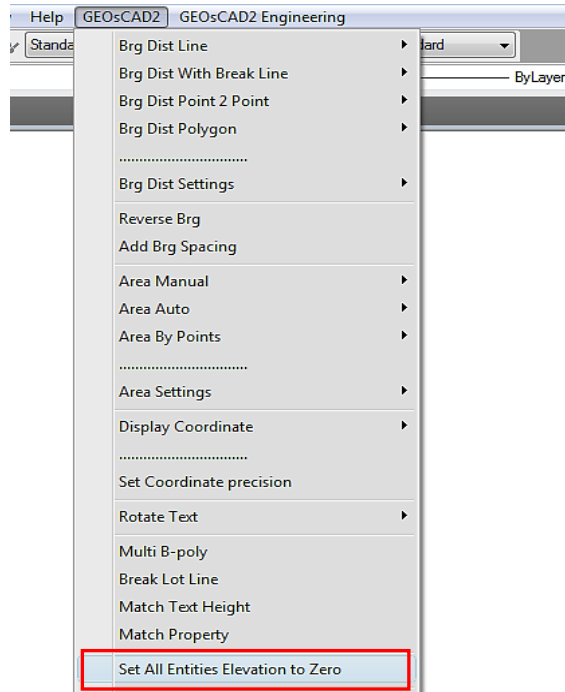

(Figure 9.1)

2. Select objects and then press Enter

3. Example:

Illustration 1: Before set Polyline Elevation to zero

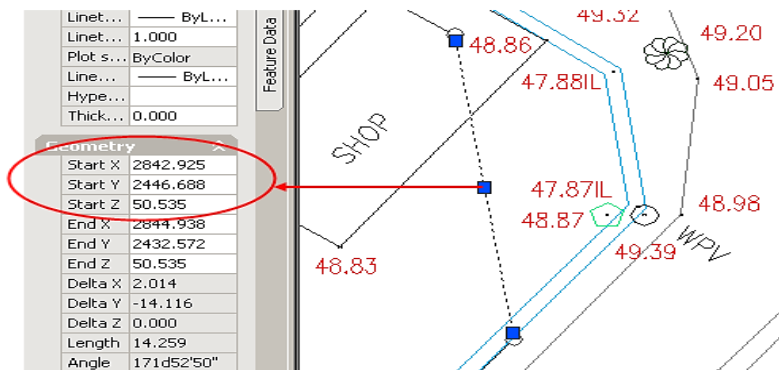
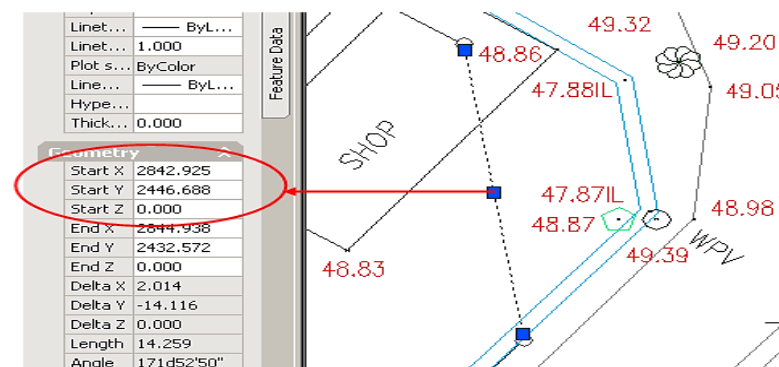

Illustration 2: After set Polyline Elevation to zero



Function 10: Offset

10.1 Offset Lots

Function Description: Offsetting creates a new object whose shape parallels the shape of a selected object.

1. From the GeoSCAD2 menu, choose [**Offset Lots**]. (Refer *Figure 10.1*)

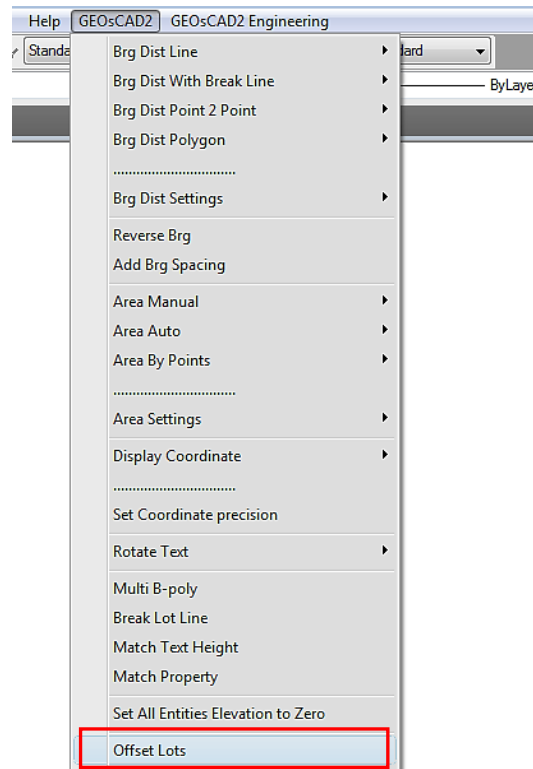

(Figure 10.1)

2. Specify the number of offsets. Eg. Enter **4**
3. Specify the offset distance eg. Enter **6.096** and press **Enter**.
4. Select the line to offset.
5. Specify any point on the side of line.
6. Example:

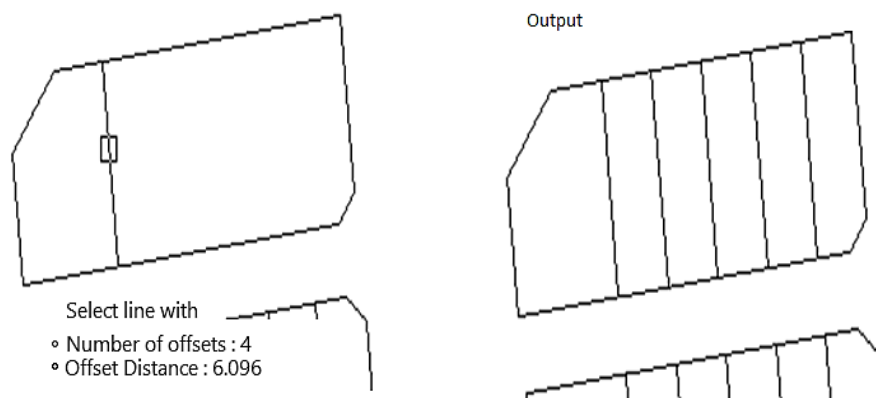

10.2 Offset Text

Function Description: To copy a selected text by specifying a distance (specify the first and second point) and the number of text to offset.

1. From the GeoSCAD2menu, choose **Text Offset**. (Refer Figure 10.2)

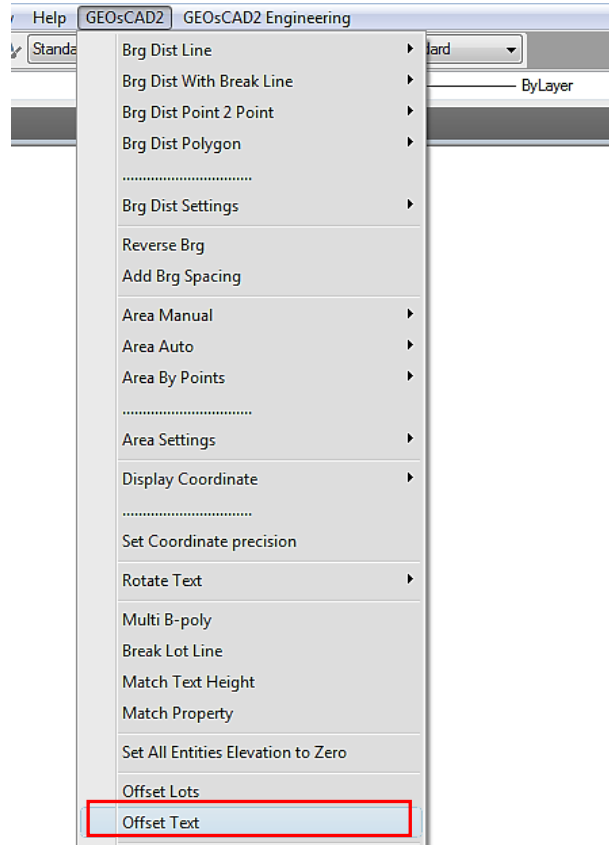

(Figure 10.2)

2. Select the text to offset and press Enter or right click mouse button.
3. Specify the first and second point by the pointing device (to set the offset distance)
4. Specify the number of text to offset and press Enter.

Example:

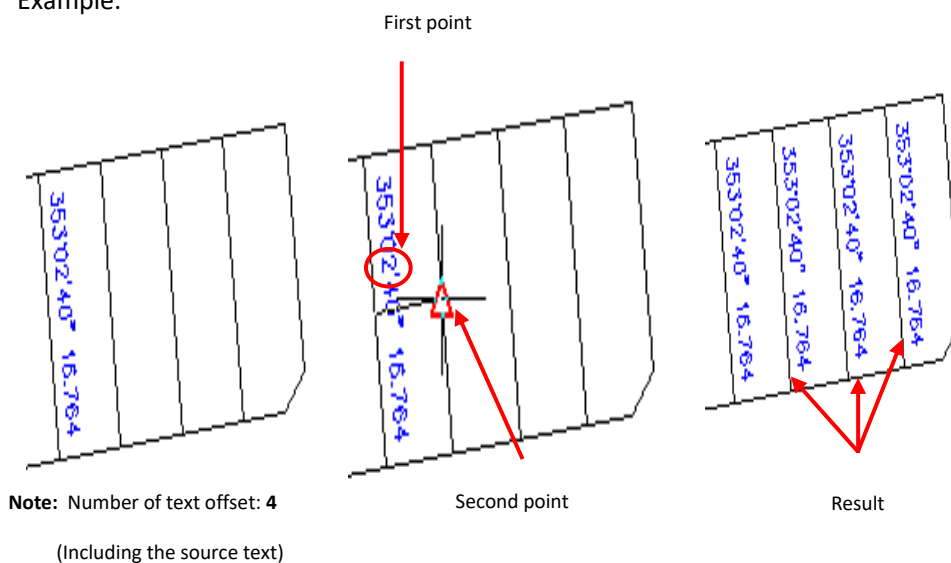

Function 11: Insert Boundary Marks Symbols

Function Description: To insert boundary marks symbols.

1. From the GeoSCAD2 menu, click [Insert Boundary Marks Symbols] and Choose one of the insert boundary marks option. **(Refer Figure 11.1)**

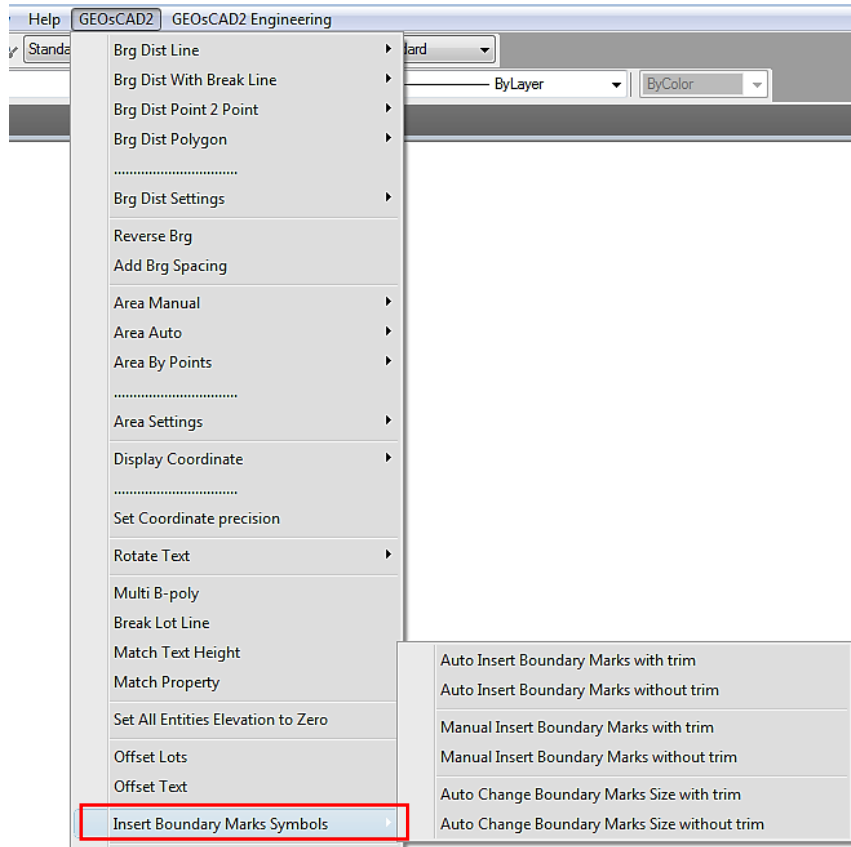

(Figure 11.1)

2. Select objects (you can use any selection method) and then right click mouse button to insert the boundary marks.
3. If you choose Manual Insert boundary marks (with trim or without trim) in step 1, the window command will prompt you to select point. You need to select point one by one.
4. The following examples illustrate the different boundary mark symbol options.

Auto insert boundary marks with trim

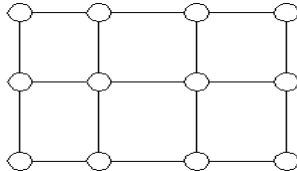

Auto insert boundary marks without trim

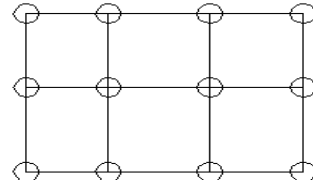

Manual insert boundary mark with

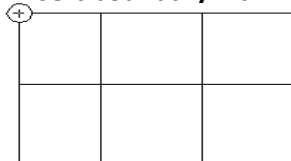

Manual insert boundary mark without trim

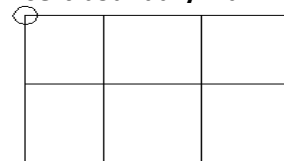

Function 12: Traverse Line

Function Description: To create an object, such as a line or an arc using bearing and distance entry

- From the GeoSCAD2 menu, choose **[Traverse Line]**. (Refer *Figure 12.1*)

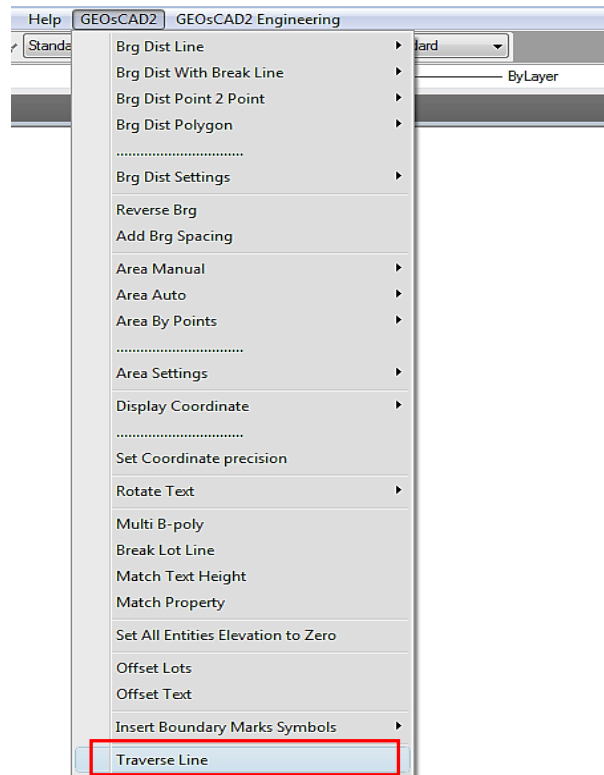

(Figure 12.1)

- Specify the starting point by use pointing device or enter the x, y coordinate.
- Enter the integer label (optional) "STN" number
- Enter the angle 125deg 30'30"
- Enter the angle using the current angular units setting – 125.3030
- Enter the distance
- Repeat step to continue.
 - If you set none for step 3, repeat step 4 – 5
 - If you set integer STN label, repeat step 3 – 5 (refer example below)

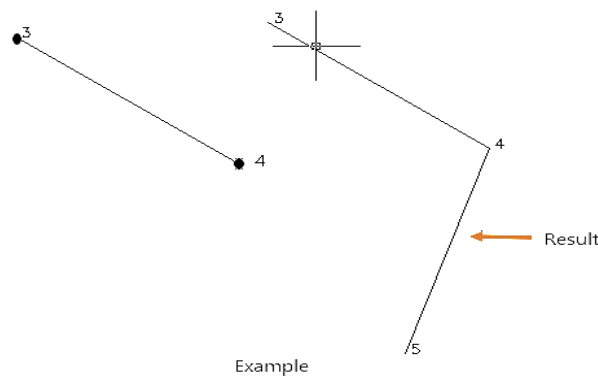

- Press Esc to cancel

Function 13: Radiate Line from Station

Function Description: To plot the radiate line from station

1. From GeoSCAD2 menu, choose [**Radiate Line from Stn.**] (Refer *Figure 13.1*)
2. The command window will prompt you to start point.
3. You can start point by picking any point or specify the coordinate
4. On command line, enter new integer label or press enter for none
5. Enter the bearing ➤ Enter the distance.
6. On command line, enter the next integer label or presses enter to accept the current value.
7. Repeat step 4 to 5 to continue
8. Press Esc to cancel.

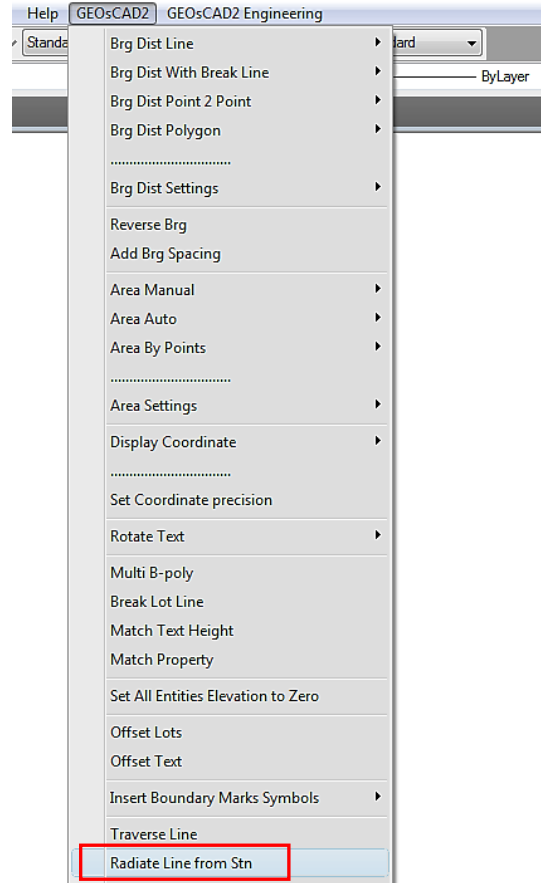

(Figure 13.1)

9. Example:

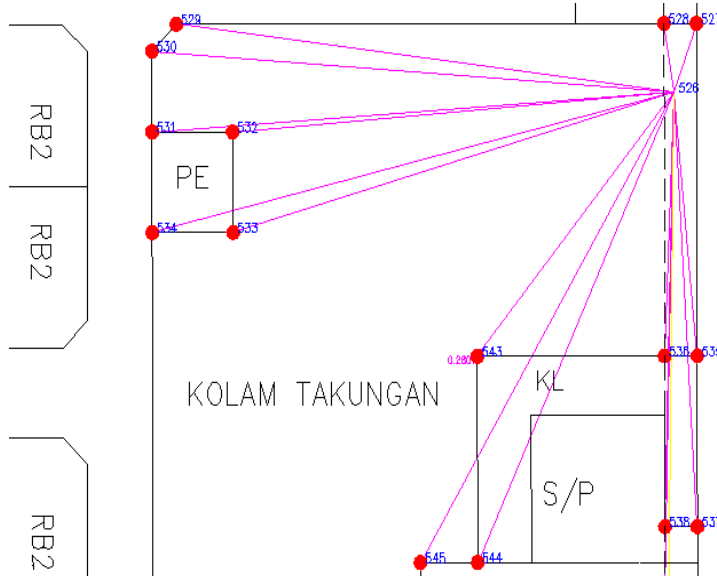

Function 14: Traverse Line Function

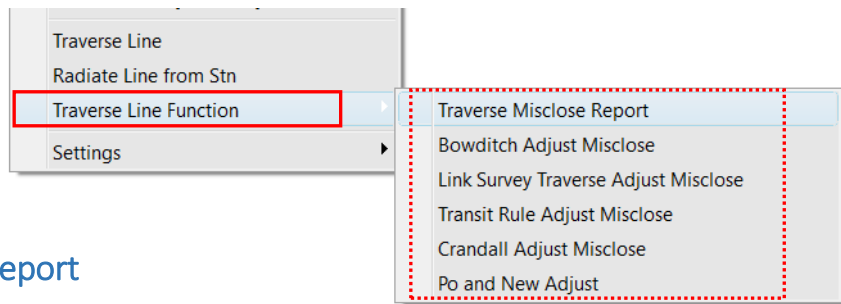

14.1 Traverse Misclose Report

Function Description: To display the traverse misclose ratio

1. From the GeoSCAD2 menu, choose **[Traverse Line Function]** ➤ Traverse Misclose Report
2. Specify the starting and end point
3. Select object and then right click mouse button to see a result of traverse misclose ratio.
4. Example:

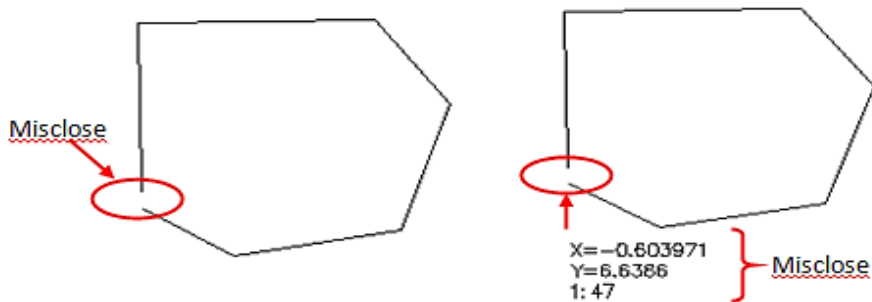

14.2 Bowditch Adjust Misclose

Function Description: To display the traverse bowditch adjustment

1. From the GeoSCAD2 menu, choose **[Traverse Line Function]** ➤ Bowditch Adjust Misclose
2. Picking the starting point on traverse
3. Select object and then enter to reconfirm
4. Click any place to display a result of Bowditch adjust misclose

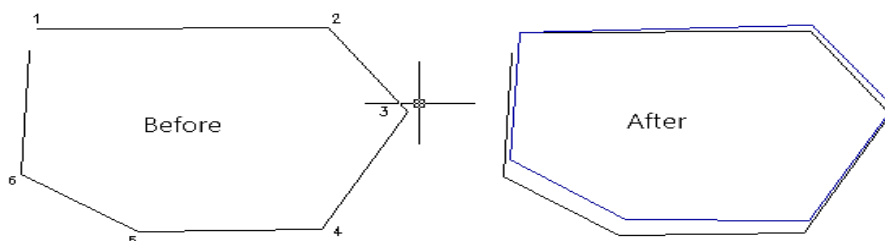

Bowditch Adjustment					
Ori Bearing	Ori Dist	New Bearing	New Dist	Mis Lot	Mis Dep
89°37'14"	17.040	88°09'12"	17.169	-1.658	-0.452
144°09'50"	8.049	142°56'57"	7.916		
208°52'28"	10.480	209°14'41"	10.188		
288°48'23"	10.836	270°17'23"	10.757		
303°41'24"	8.137	305°08'02"	8.209		
2°40'44"	9.637	3°00'17"	9.889		

Example

14.3 Transit Rule Adjust Misclose

Function Description: To display the traverse transit rule adjustment misclose

1. From the GeoSCAD2 menu, choose **[Traverse Line Function]** ➤ **Transit Rule Adjust Misclose**
2. Picking the starting point on traverse
3. Select object and then enter to reconfirm
4. Click any place to display a result of transit rule adjust misclose
5. Example:

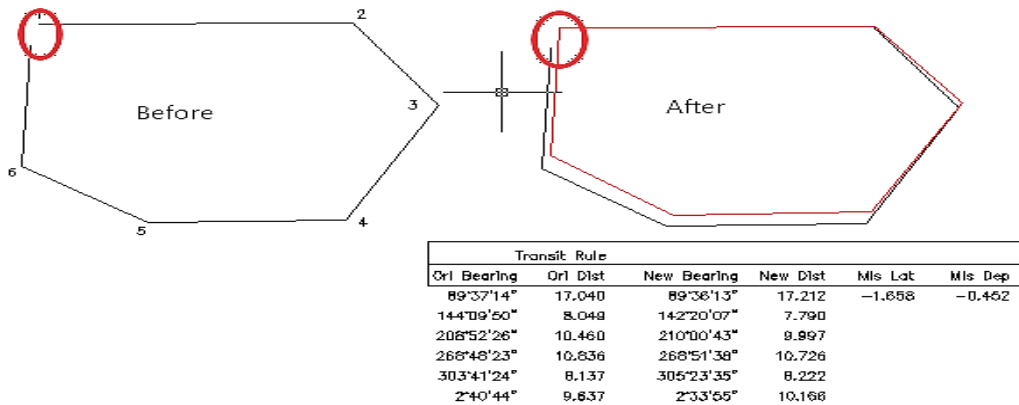

Example

14.4 Crandall Adjust Misclose

Function Description: To display the Crandall Adjustment misclose

1. From the GeoSCAD2 menu, choose **[Traverse Line Function]** ➤ **Crandall Adjust Misclose**
2. Picking the starting point on traverse
3. Select object and then enter to reconfirm
4. Click any place to display a result of Crandall adjust misclose
5. Example:

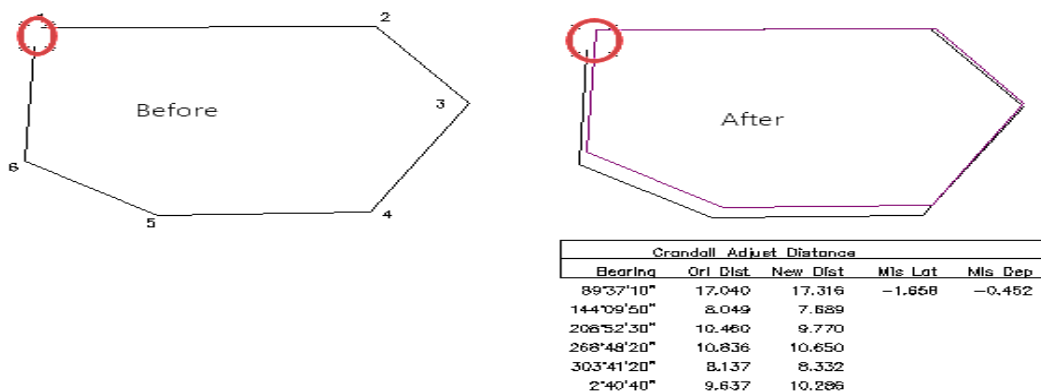

Example

14.5 Link Survey Traverse Adjust Misclose v.18.6

Function Description: To display the Link Survey Traverse bowditch adjustment misclose.

1. From the GeoSCAD2 menu, choose **[Traverse Line Function] >** Link Survey Traverse Adjust Misclose. v.18.6
2. Please select the start point of the Link Survey traverse (endpoint snap - **Point A**)
3. Select all the Link Survey traverse line objects (All lines from **Point A to Point B**)
4. Please select Link point (endpoint snap - **Point C**)
5. Please select a display point (endpoint snap – **Point A**)

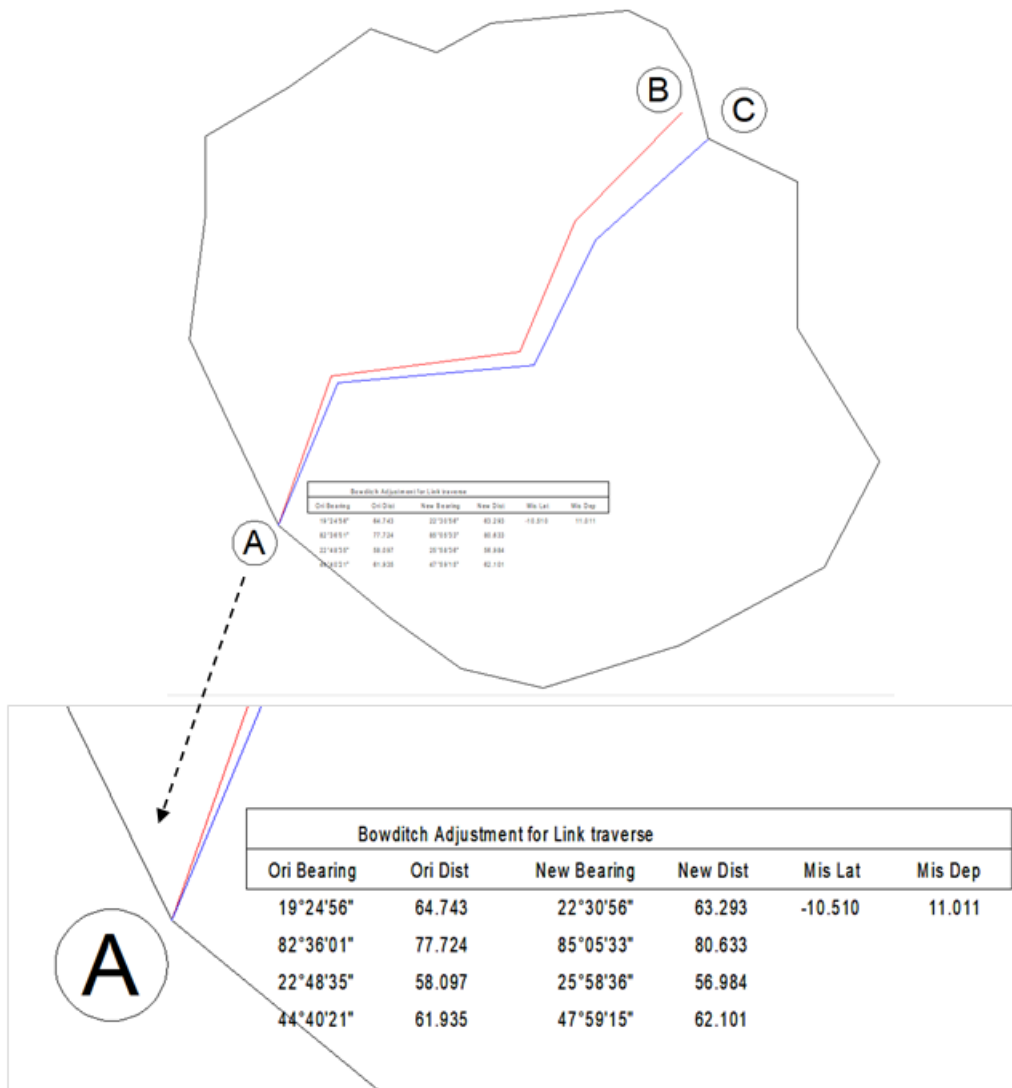

14.6 Po and New Adjust

Function Description: To display PO and new adjustment.

1. Firstly, create the traverse using manually or enter into the notepad.

training doc - Notepad

File Edit Format View Help

```
138.3620 198.849
170.5830 48.049
180.3430 68.408
180.4000 65.200
```

Using Notepad

Command:

Start point:

Enter new integer label or enter for none:

Enter bearing: 138.3620

Enter distance in Meter :

Manually

2. Result (refer example below)

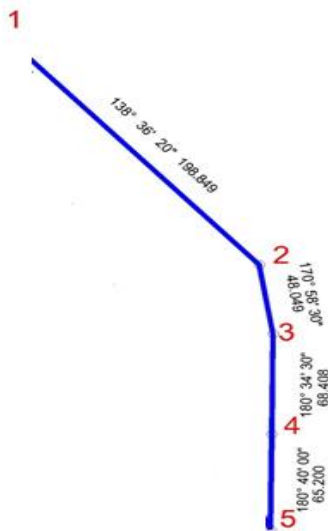

Example

3. From the GeoSCAD2 menu, choose **[Traverse Line Function] > PO and new adjustment**
4. Select first point, and then select the object, after those clicks enter.
5. The PO Bearing and PO distance will show on command (337°22'57'' and dist 357.739).
6. Enter new bearing (337°23'10'' and dist 357.789).
7. Select a display point (nearest to the drawing) and Esc to cancel.

8. Example :

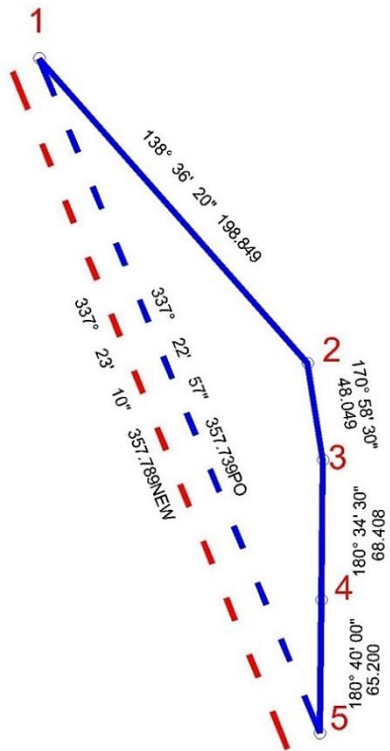

Example

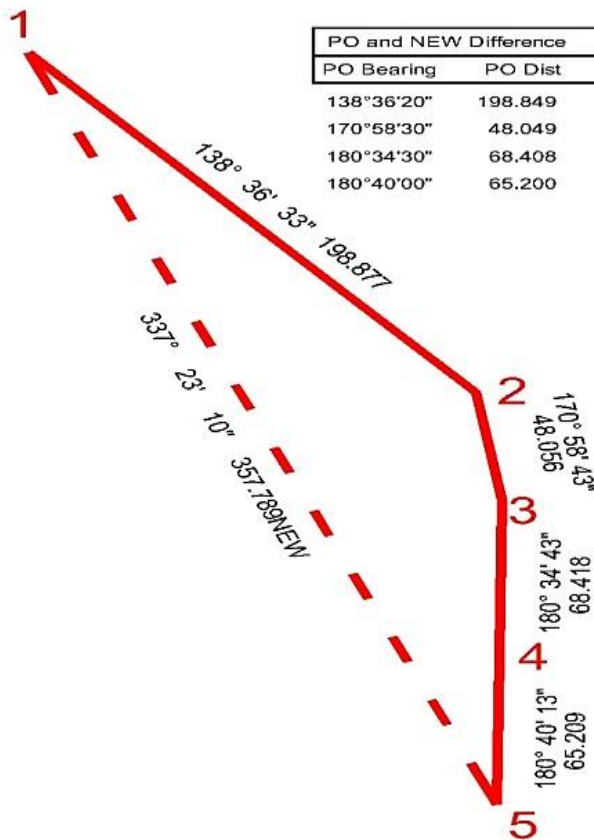

PO and NEW Difference		+0°00'13"	0.050
PO Bearing	PO Dist	Adj PO Bearing	Adj PO Dist
138°36'20"	198.849	138°36'33"	198.877
170°58'30"	48.049	170°58'43"	48.056
180°34'30"	68.408	180°34'43"	68.418
180°40'00"	65.200	180°40'13"	65.209

GEOsCAD2 ENGINEERING

Function 15: Plot Cutting

15.1 Plot Cutting Civil Engineer's Symbol

Function description: To show a slope symbol

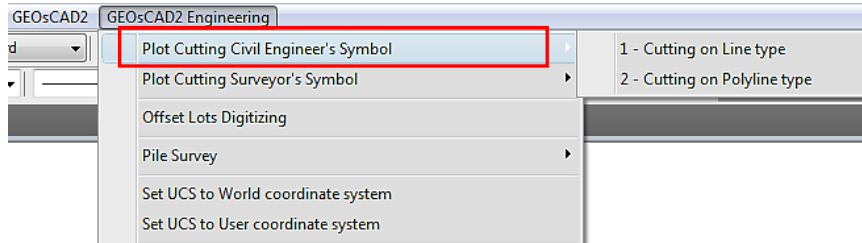

(Figure 1.1)

1. From GeoSCAD2 Engineering menu, choose **[Plot Cutting Civil Engineer's Symbol]** (Refer Figure 1.1) ➤ Select :
 - Cutting on Line type
 - Cutting on Polyline type
2. On command line enter the new interval value or presses enter to accept the current default value.
3. The command window will prompt you to select the top cutting ➤Select objects and then right click mouse button to proceed.
4. The command window will prompt you to select the bottom cutting ➤select objects and then right click mouse button.
 - Cutting on Line type
 - Cutting on Polyline type

Example 1: Cutting on Line type

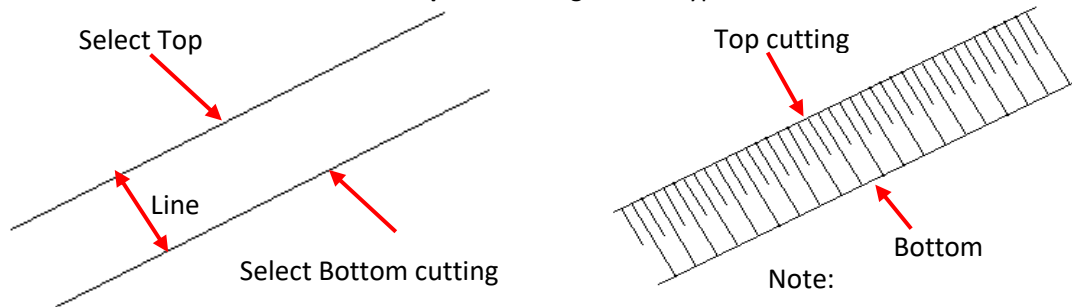

Example 2: Cutting on Polyline type

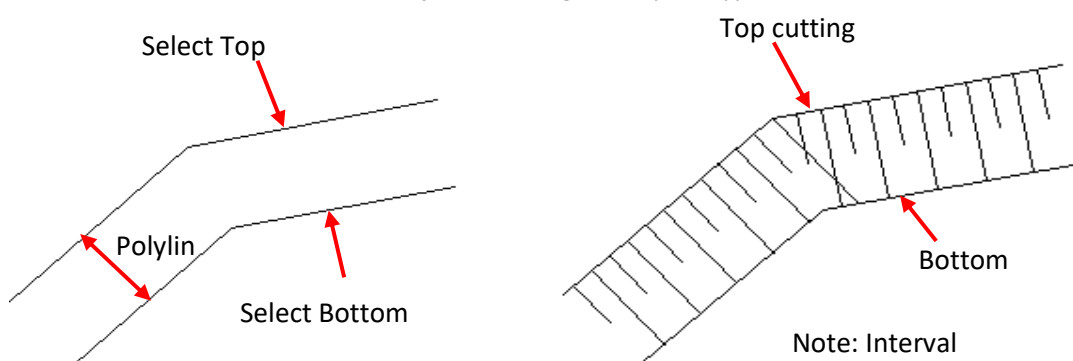

15.2 Plot Cutting Surveyor's Symbol

Function description: To show a slope symbol

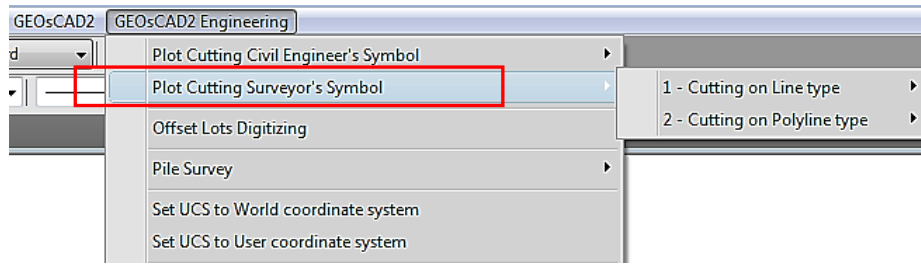

(Figure 1.2)

1. From GeoSCAD2 Engineering menu, choose [**Plot Cutting Surveyor's Symbol**] (Refer **Figure 1.2**) ➤ Select
 - Cutting on Line type
 - Cutting on Polyline type
2. On command line enter the new interval value or presses enter to accept the current default value.
3. The command window will prompt you to select the top cutting ➤ Select objects and then right click mouse button to proceed.
4. The command window will prompt you to select the bottom cutting ➤ select objects and then right click mouse button.

Example 1: Cutting on Line type

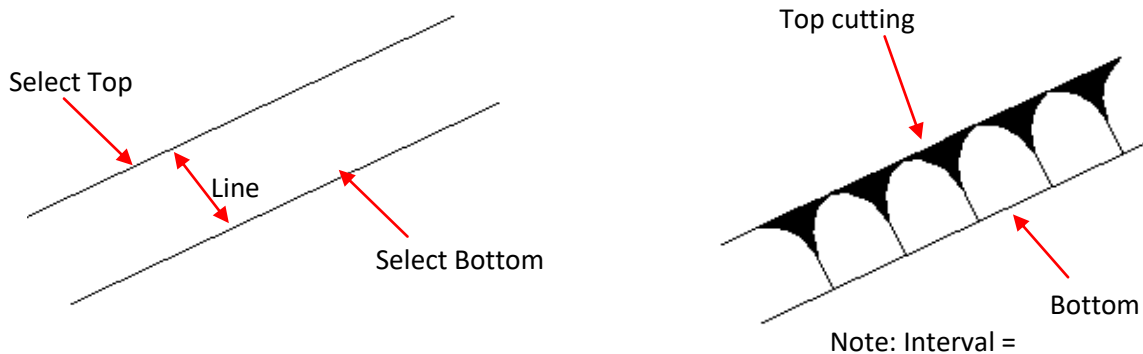

Example 2: Cutting on Polyline type

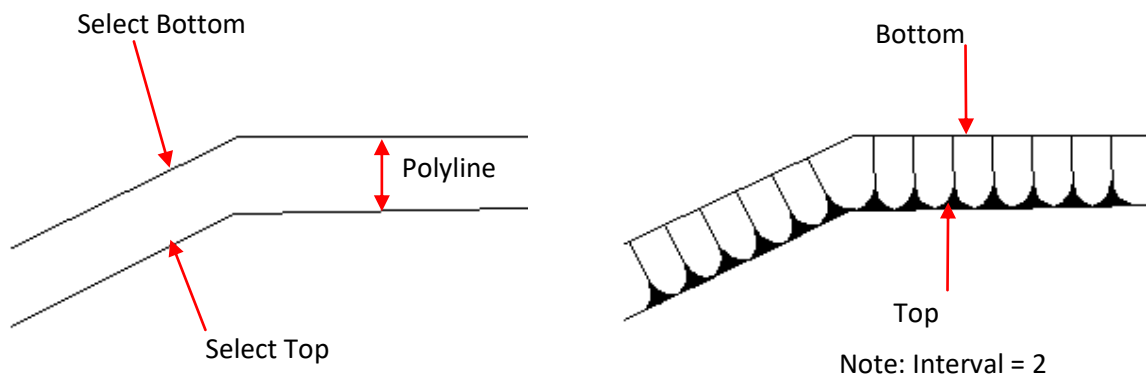

Function 16: Offset Lots Digitizing

Function description: To measure perpendicularly from a main line.

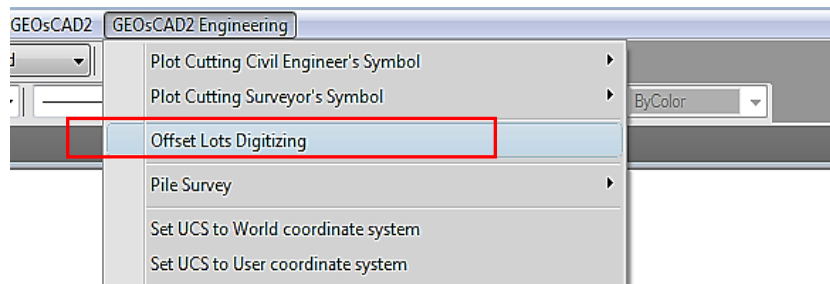

(Figure 2)

1. From GeoSCAD2 Engineering menu, choose **[Offset Lots Digitizing]** (refer *Figure 2*)
2. On command line enter number of offsets , press **Enter**
3. On command also, pick the object that need to copy e.g. 8, continue by clicking the endpoint. Refer example below

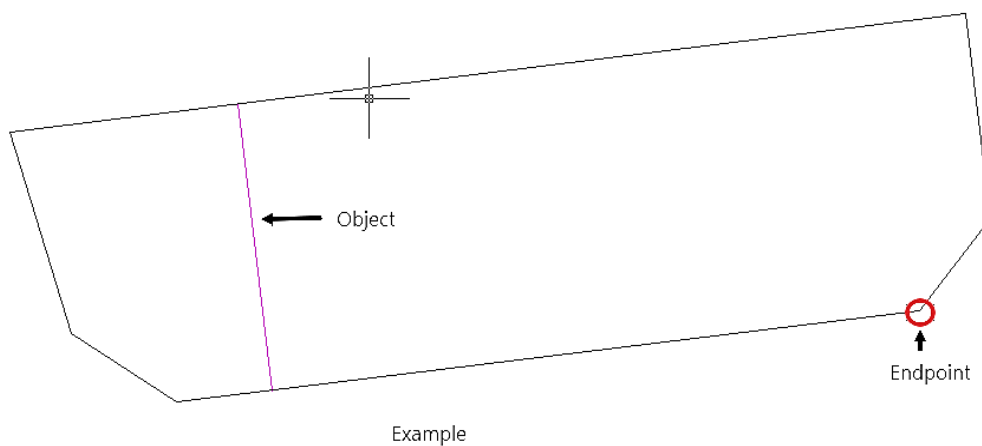

4. Result

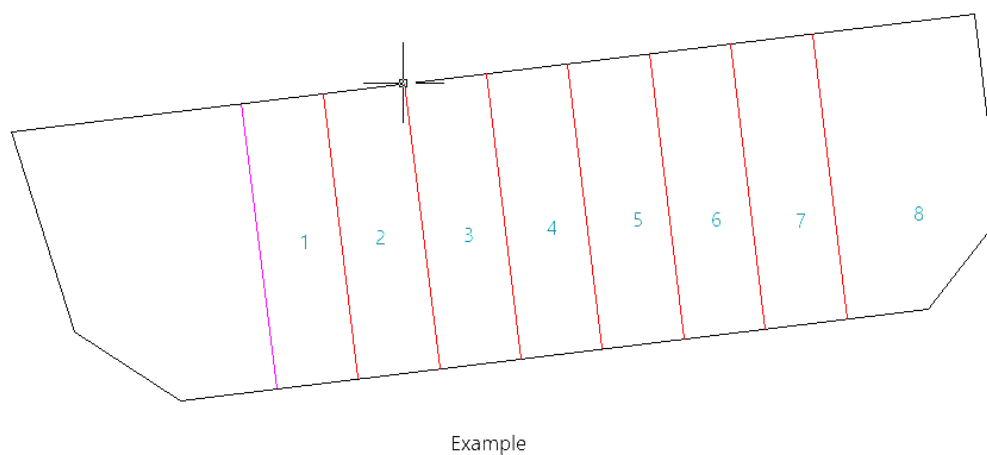

Function 17: Pile Survey

17.1 Set Pile Number

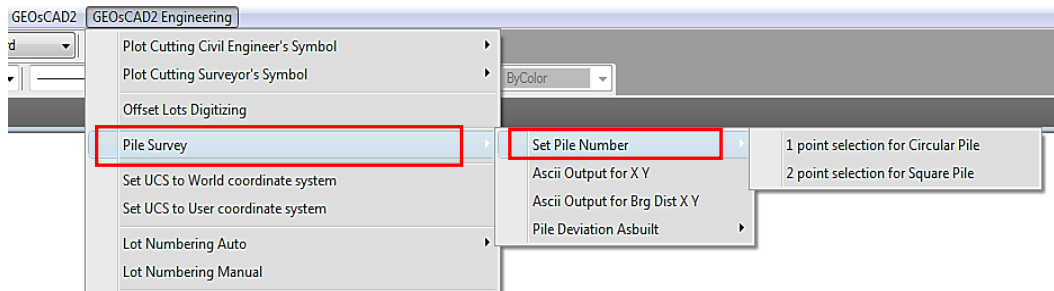

(Figure 17.1)

1. From the GeoSCAD2 Engineering menu, choose **[Pile Survey] (Refer Figure 17.1)** ➤ Set Pile number.
2. Select Point Selection for Square Pile.
3. The command window will prompt you to enter new integer point label or enter for none.
4. See illustration below:

```
Select Point format [ 1PNT | 2PNT ] : 2PNT ← Square Pile
Enter new integer point label or enter for none: 200
```

Specify point 1 and point 2 (See illustrations below)

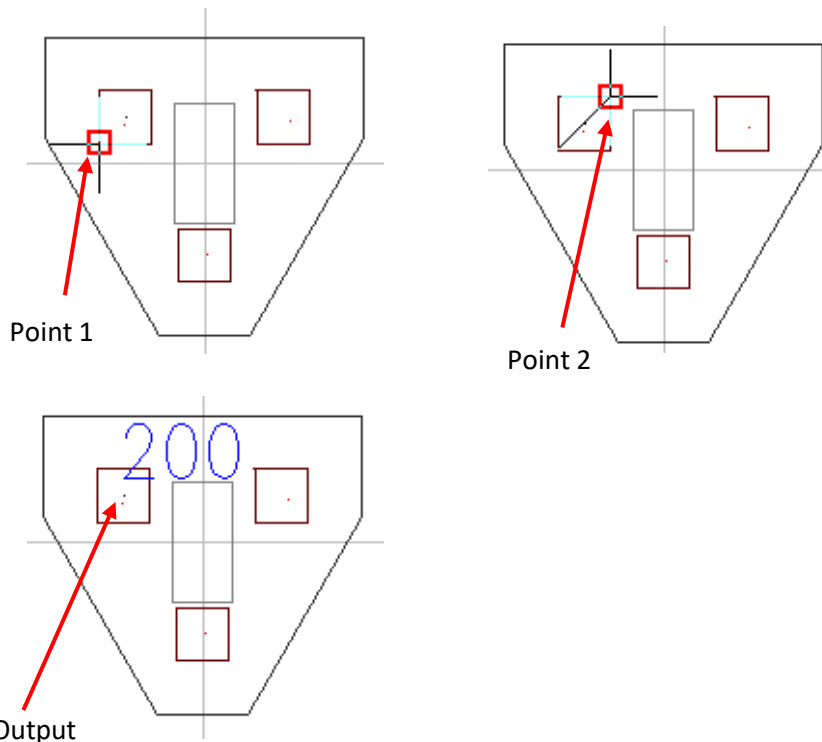

Repeat step 4 to continue.

17.2 ASCII Output for X Y

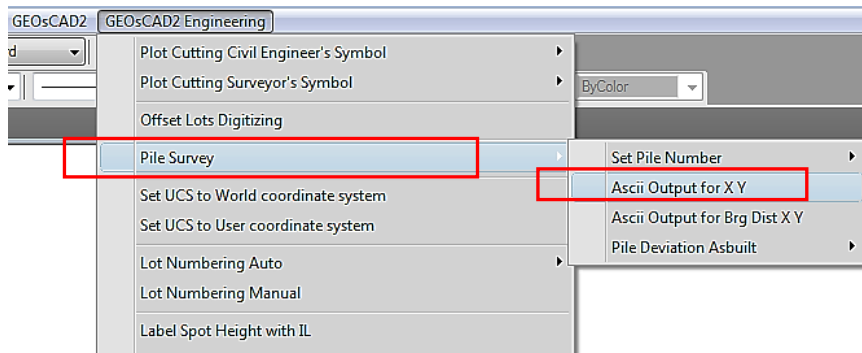

(Figure 17.2)

1. From the GeoSCAD2 Engineering menu, choose **[Pile Survey]** ➤ ASCII Output for X Y
2. The command window will prompt you to enter new integer point label or enter for none. See illustration below:

Enter new integer point label or enter for none: 300

3. On command line, enter new integer point label and then press Enter.
4. Select objects and then right click mouse button to complete the command
The Pile number automatically generated for selected objects.
(See example in illustration below)

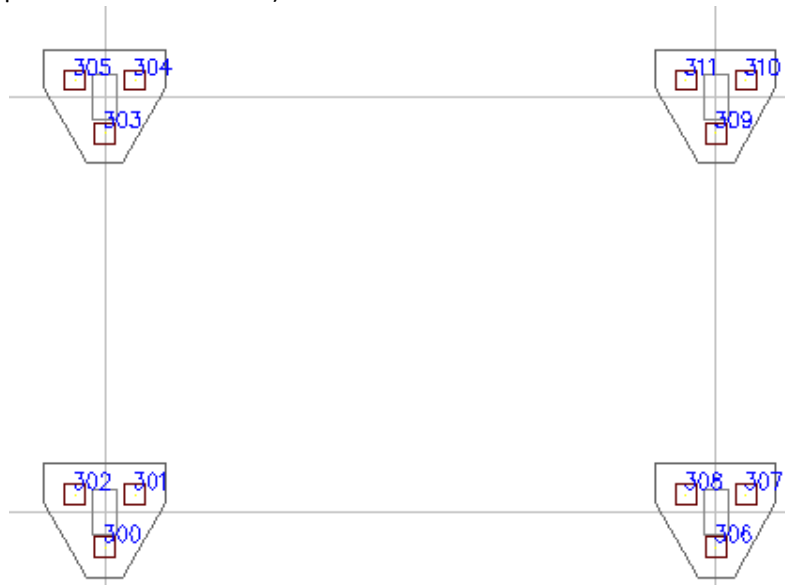

One ASCII file also generated automatically by using this function.

The files name called **filexy.txt** and save under **C:/geoscad2** folder. (See example in illustration below)

File	Edit	Format	Help
300	228251.621	24365.047	Pt
301	228251.921	24365.572	Pt
302	228251.321	24365.572	Pt
303	228251.621	24369.171	Pt
304	228251.921	24369.696	Pt
305	228251.321	24369.696	Pt
306	228257.717	24365.047	Pt
307	228258.017	24365.572	Pt
308	228257.417	24365.572	Pt
309	228257.717	24369.171	Pt
310	228258.017	24369.696	Pt
311	228257.417	24369.696	Pt

17.3 ASCII Output for Brg Dist X Y

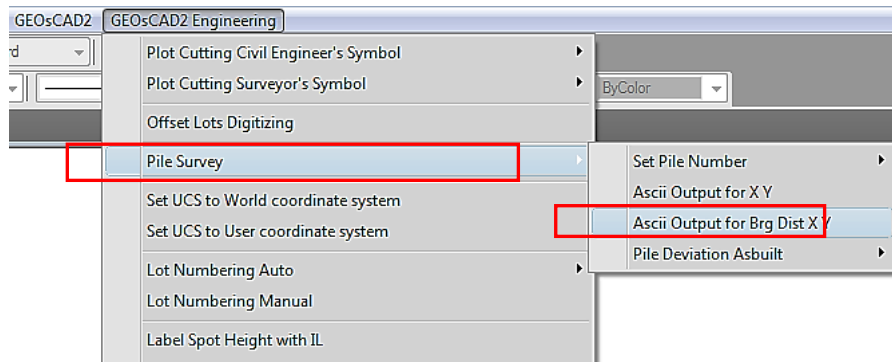

(Figure 17.3)

Note: To use this function you must have the pile number

1. From the GeoSCAD2 Engineering menu, choose **[Pile Survey]** (Refer **Figure 17.3**) ➤ ASCII Output for Brg Dist X Y.
2. Select Station No. by picking station point (see example in illustration below).

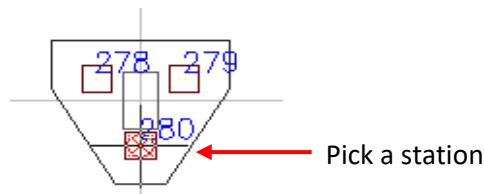

3. Select objects and then right click button to complete the command.
One ASCII file will be generated automatically. The file names called **filebdxy.txt** and save under **C:/geoscad2** folder. (See example in illustrations below)

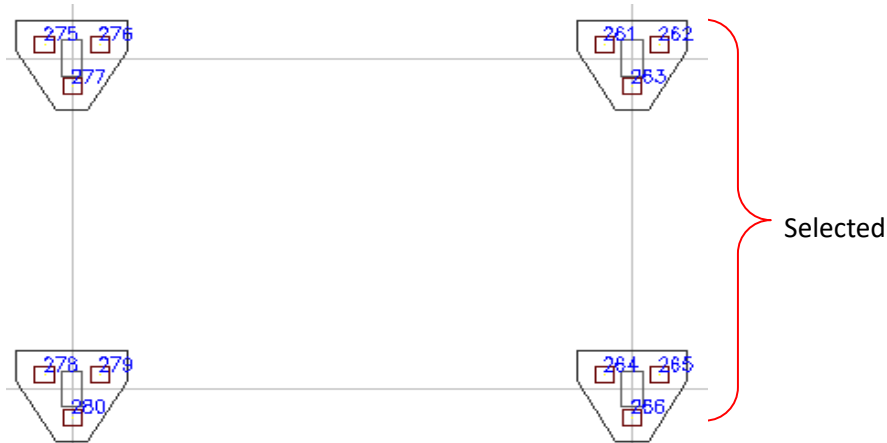

No	Bearing	Jarak	Utara	Timur
280	90 d 00' 00"	0.000	228251.621	24365.047
279	29 d 44' 40"	0.605	228251.921	24365.572
278	330 d 15' 20"	0.605	228251.321	24365.572
277	0 d 00' 00"	4.124	228251.621	24369.171
276	3 d 41' 30"	4.659	228251.921	24369.696
275	356 d 18' 30"	4.659	228251.321	24369.696
266	90 d 00' 00"	6.096	228257.717	24365.047
265	85 d 18' 30"	6.418	228258.017	24365.572
264	84 d 49' 30"	5.820	228257.417	24365.572
263	55 d 55' 20"	7.360	228257.717	24369.171
262	53 d 59' 20"	7.907	228258.017	24369.696
261	51 d 16' 00"	7.430	228257.417	24369.696

Output:

17.4 Pile Deviation Asbuilt

Function description: To calculate the eccentricity of pile position

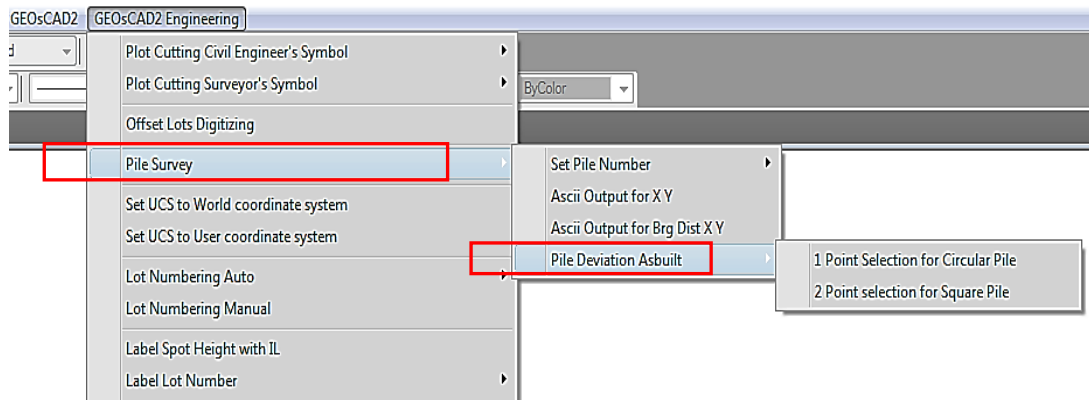

(Figure 17.4)

1. From the GeoSCAD2 Engineering menu, choose **[Pile Survey] (Refer Figure 17.4) ➤ Pile Deviation Asbuilt.**
2. You have two options whether you want to use:
 - Select Point Selection for Circular Pile **or**
 - Select Point Selection for Square Pile
3. The command window will prompt you to select a point1 and then Point 2.
4. Select point 1 and 2.
5. Select the second point ➤ Specify the base point or displacement
6. Specify second point of displacement or use first point as displacement.
7. Example (see illustration below)

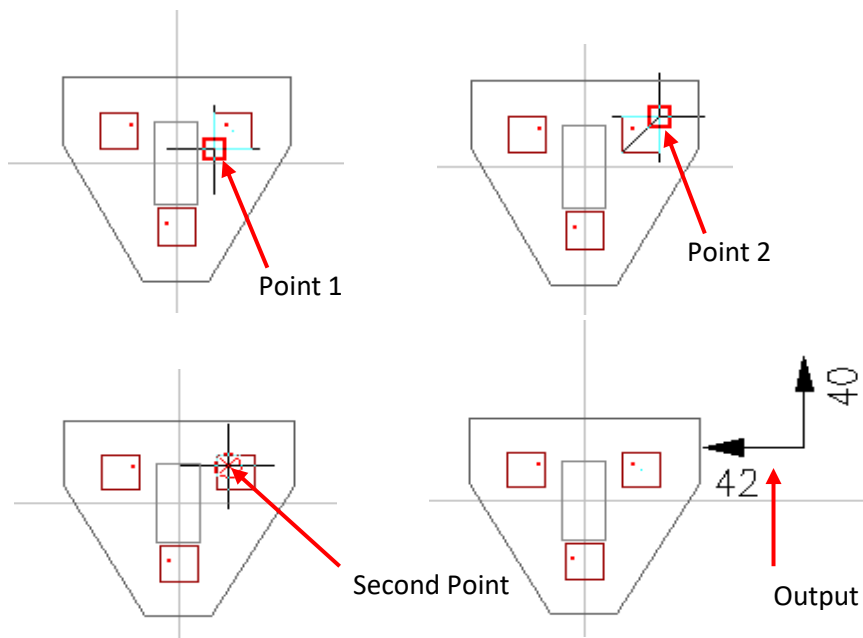

Note: This example for Pile Deviation As built ➤ Point Selection for Square Pile

Function 18: Set UCS

18.1 Set UCS to World coordinate system

Function Description: To set UCS (user coordinate system) to world coordinate system

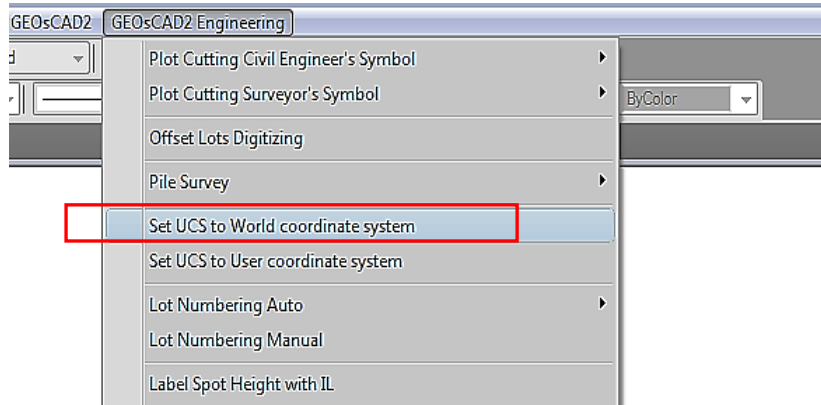

(Figure 18.1)

1. From GeoSCAD2 Engineering menu, choose [**Set UCS to World coordinate system**] (Refer Figure 18.1).
2. The command window will prompt you to specify the new origin (See illustration below)

```
Command: ucsu ucs
Current ucs name: *WORLD*
Enter an option [New/Move/orthoGraphic/Prev/Restore/Save/Del/Apply/?/World]
<World>: 3
Specify new origin point <0,0,0>:
```

- I. Specify new origin by picking a point (see illustration beside)

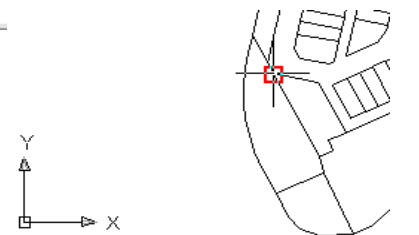

- II. Specify X point by picking a point (see illustration beside)



- III. Specify Y point by picking a point (see illustration beside)

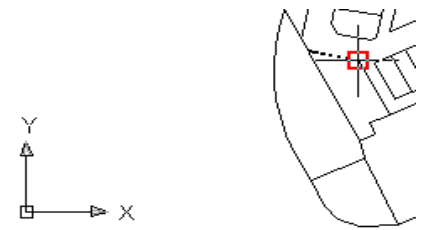

- IV. Example output: (see illustration beside)

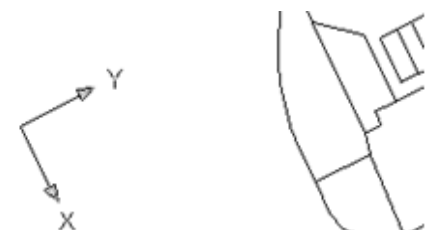

Function 19: Lot Numbering

19.1 Lot Numbering Auto

Function description: To generate auto numbering by specifying the first number, start and end point.

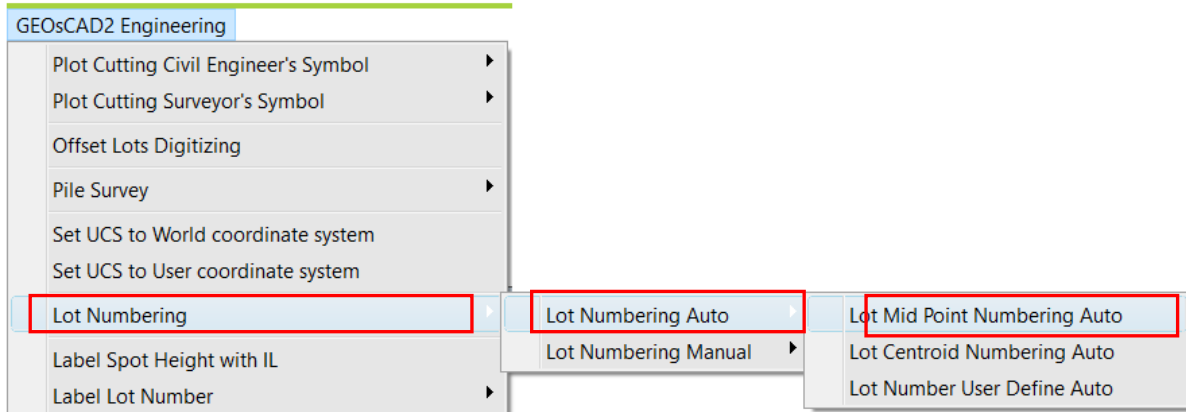

(Figure

19.1)

1. From GeoSCAD2 Engineering menu, choose [**Lot Numbering Auto**] > **Lot Mid Point Numbering Auto / Lot Centroid Numbering Auto**
2. At ask confirm boundary selection? [y | n] <Current> prompt, enter 'y' or 'n' and press Enter
 - **Yes:** This setting will prompt user for confirmation of every lot boundary
 - **No:** This setting will skip the lot boundary confirmation from user
3. Please enter the next lot number <1>: eg. **300** and then **press Enter**.
4. Please select a line to align text to <90d>: refer to below illustration.
5. **Starting point:**
(Specify the starting point and end point inside the polygon as shown in illustration below)

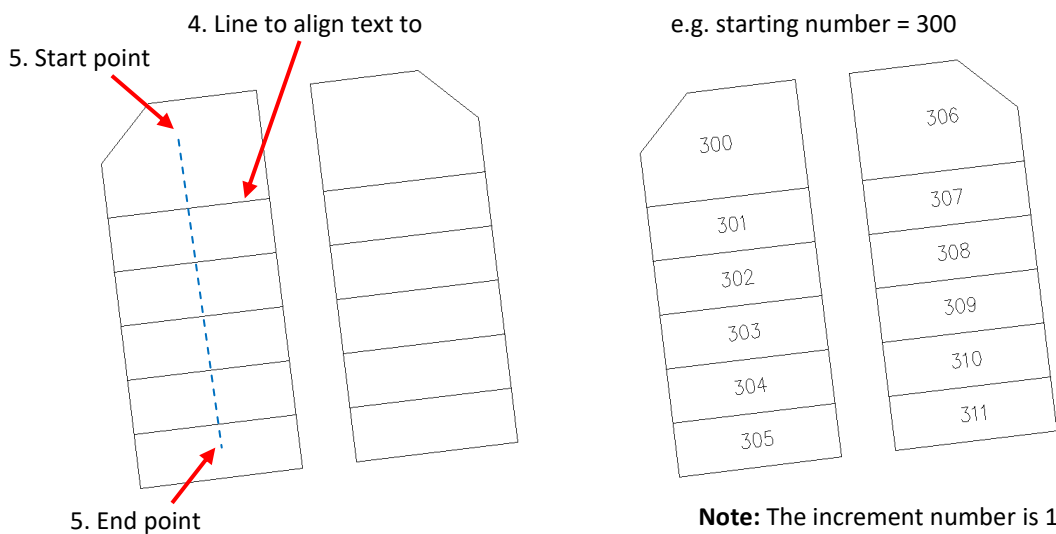

19.2 Lot Numbering Auto – User Define (v.18.6)

Function description: To generate auto numbering base on user define (Increment & Start number)

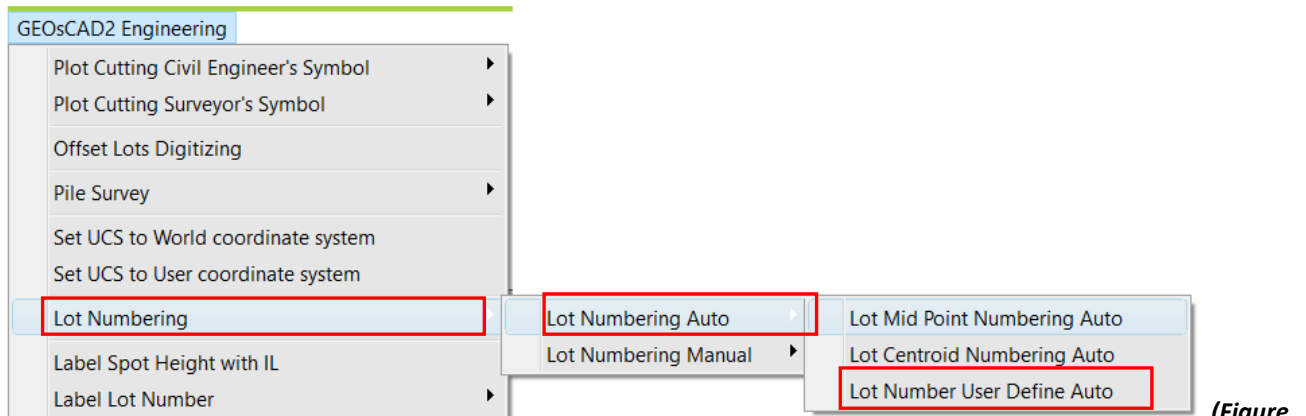

19.2)

1. From GeoSCAD2 Engineering menu, choose **Lot Numbering Auto > Lot Number User Define Auto**
2. Autonumber [+1 | +2] <Cancel>: **2**
3. *Please enter the next lot number <1>: eg. **300** and then **press Enter**.*
4. *Please select a line to align text to <90d>:*
5. *Starting point:*
(Specify the starting point and end point inside the polygon as shown in illustration below)

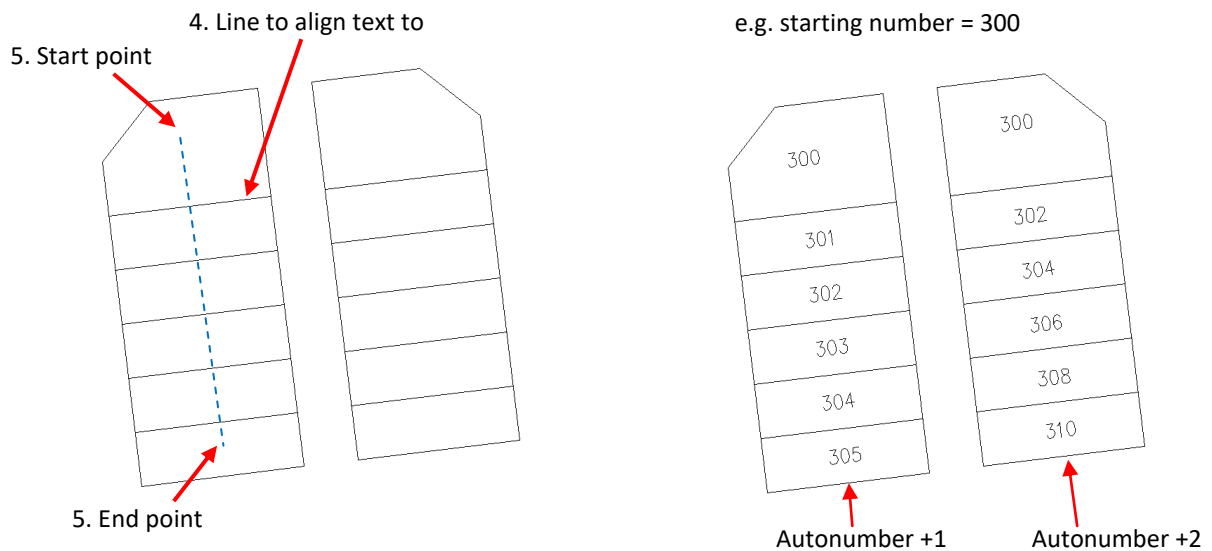

19.3 Lot Numbering Manual

Function description: To generate the number by picking a point manually.

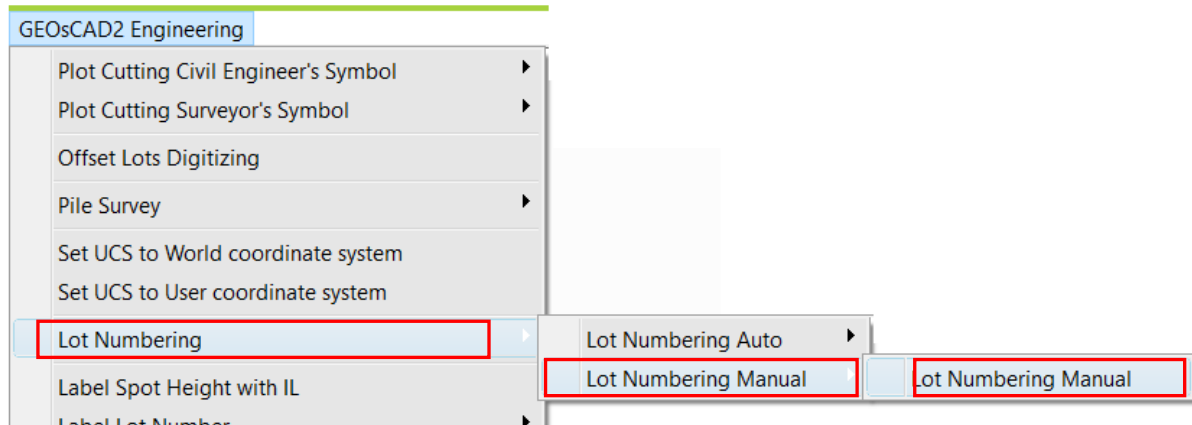

(Figure

19.3)

1. From GeoSCAD2 Engineering menu, choose **Lot Numbering Manual** ➤ [Manual Numbering].
2. Autonumber [+1 | +2] <Cancel>: 2
3. Please enter starting value <1> : 500
4. Please select a point:
5. Repeat Step 4. or Esc to cancel

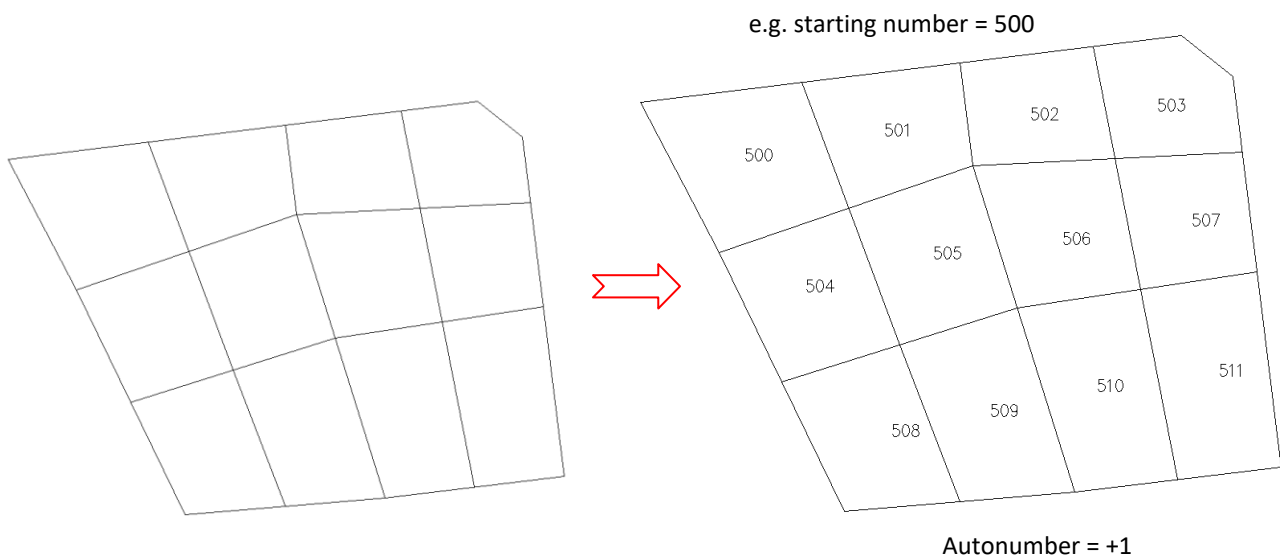

Function 20: Label Spot Height with IL

20. Label Spot Height with IL

Function description: To label spot height invert level

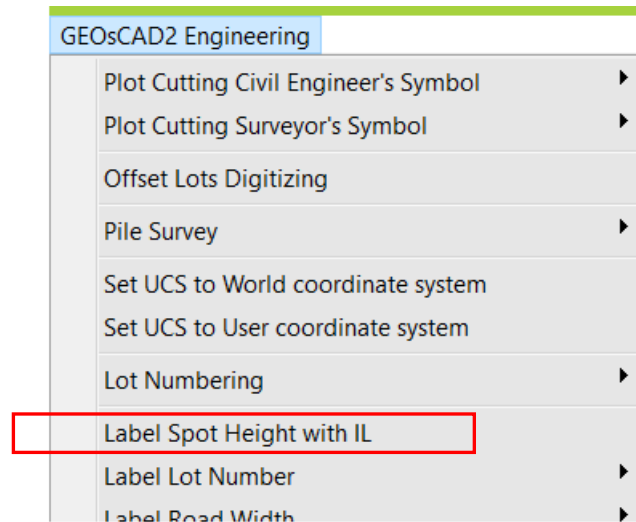

(Figure 20.)

1. From GeoSCAD2 Engineering menu, choose [Label Spot Height with IL] (Refer Figure 20).
2. Select objects and then press Enter.
3. Example:

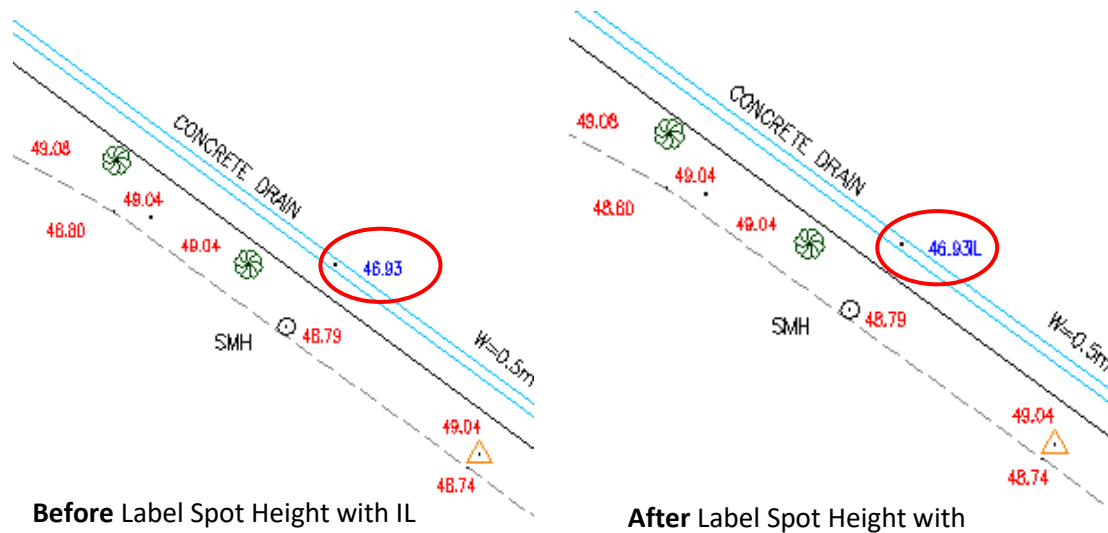

Function 21: Label Lot Number with PT / PTD / PTB...

21. Label Lot Number

Function description: To label lot number with PT, PTD or PTB

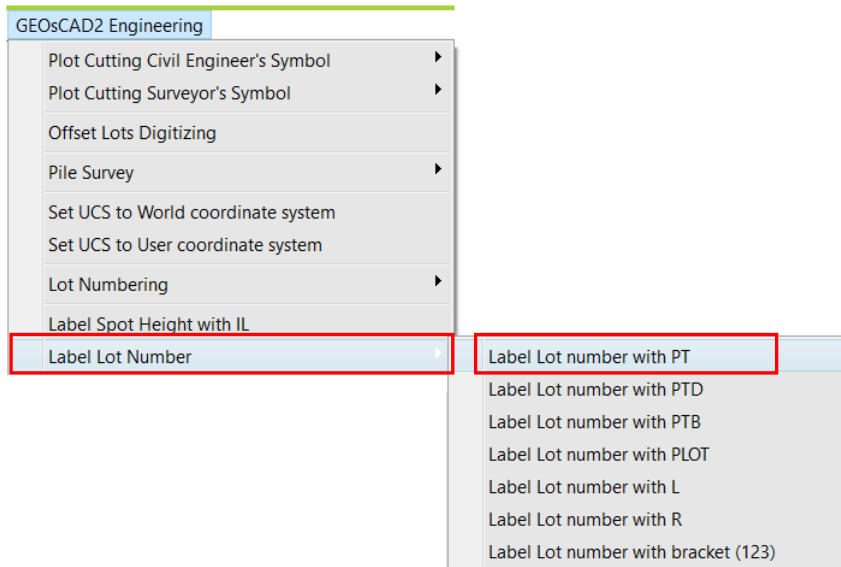

(Figure 21.)

1. From GeoSCAD2 Engineering menu, choose [Label Lot Number] (Refer Figure 21.) ➤ **Label Lot Number With PT**
2. Select objects (Lot Number) follow by Enter to complete the command.
3. Example:

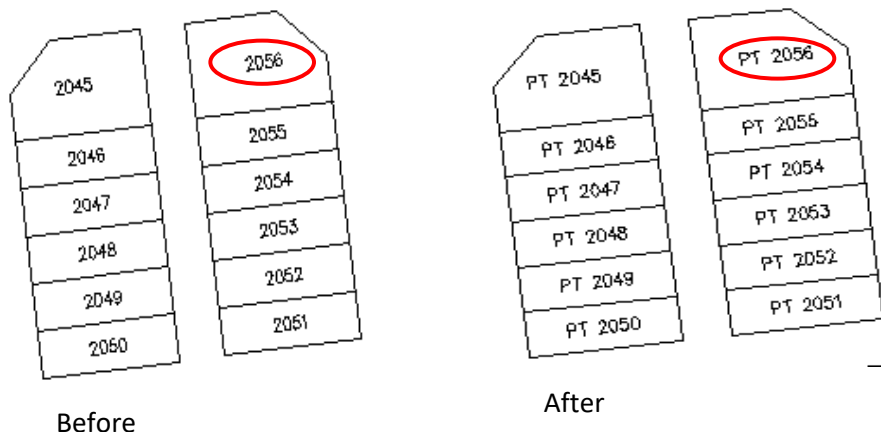

Note: This example uses Label Lot Number with PT

Function 21: Label Prefix or Suffix for Text

21-1. Label Lot No with Prefix or Suffix (v.19)

Function description: To label Lot number with Prefix or Suffix

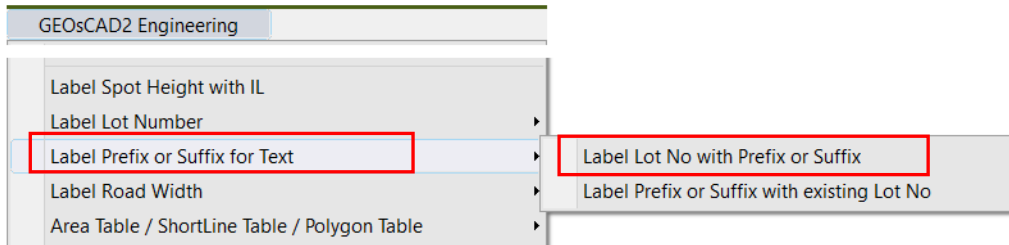

1. Refer to the above menu, choose **Label Prefix or Suffix for Text** ➤ **Label Lot No with Prefix or Suffix**

Command: wlot

Display Prefix/Suffix format [1 | 2]: 2

Ask to confirm boundary selection? [y | n] <n>: **N**

Enter Beginning Text (Prefix) : **PT**

Enter End Text (Suffix): **X**

Please enter the next lot number(Start Number) <1>:**3000**

Please select a line to align text to <90d>: **(a.)**

Current text alignment angle: 83.044444444447450d

(Specify the starting point and end point inside the polygon as shown in illustration below)

Starting point: **(b.)**

End point: **(c.)**

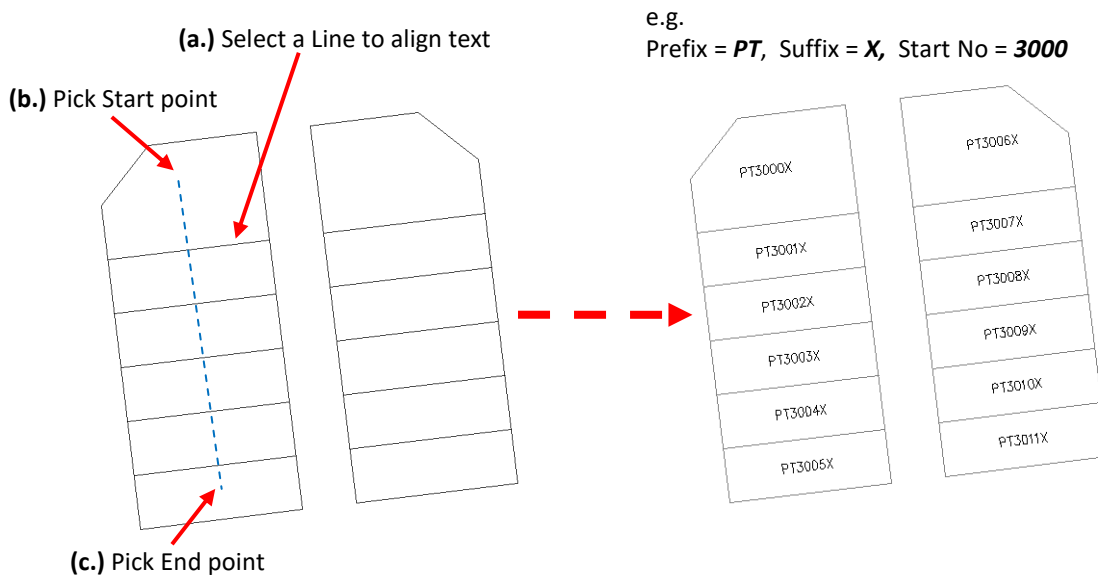

21-2. Label Prefix or Suffix with existing Lot No (v.19)

Function description: To label Existing Lot number with Prefix or Suffix

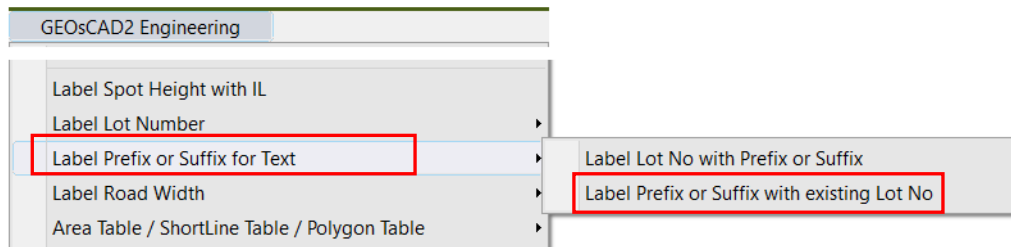

1. Refer to the above menu, choose

Label Prefix or Suffix for Text ➤ **Label Prefix or Suffix with existing Lot No**

Command: addpt2

Enter Beginning Text: **PT**

Enter End Text: **X**

Select objects: Select all the Lot numbers follow by Return key.

e.g. Prefix = **PT**, Suffix = **X**

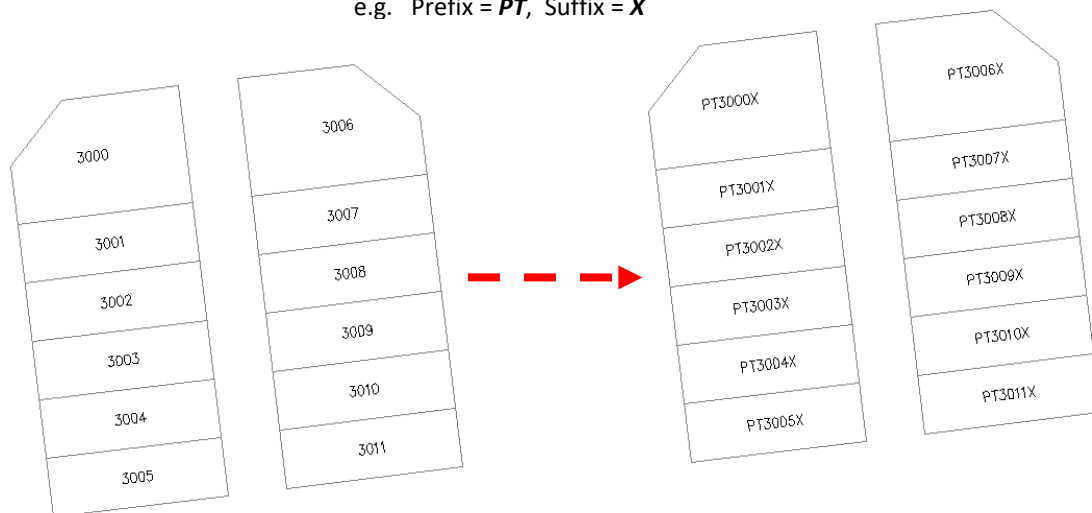

Function 22: Label Road Width

Function description: To label road width.

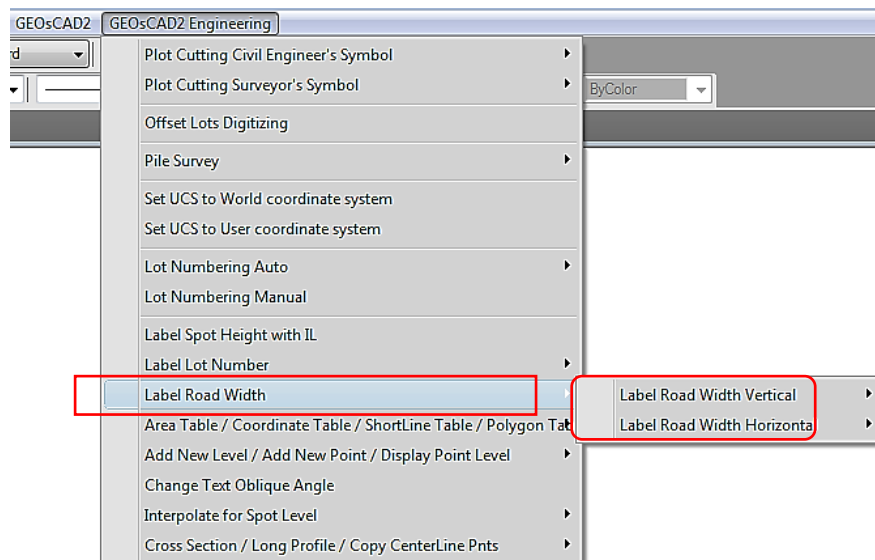

(Figure 22)

22.1 Label Road with Vertical

- Display label in vertical from select point.

 1. *Select Label Road Width → Label Road Width Vertical*
 2. *Please specify 1st and 2nd points.*
 3. *Repeat step 1 to continue or press Esc to cancel.*

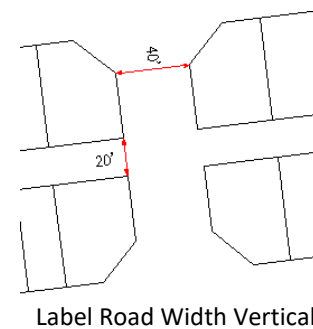

22.2 Label Road with Horizontal

- Display label in horizontal from select point.

 1. *Select Label Road Width → Label Road Width Horizontal*
 2. *Please specify 1st and 2nd points.*
 3. *Repeat step to continue or press Esc to cancel.*

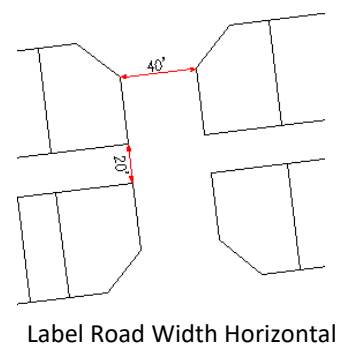

Function 23: Table (Area & Bering Distance)

23.(a) Area Table (update)

Function description: To create area table base on selected area text layer.

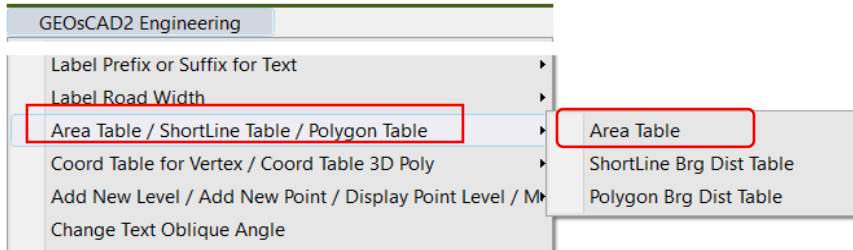

(Figure 23.1)

1. From GeoSCAD2 Engineering menu, choose [Area Table / ShortLine Table / PolygonTable] (Refer Figure 23.1) → **Area Table**
2. Select all text objects that represent the area and follow by right click mouse button or *press Enter*

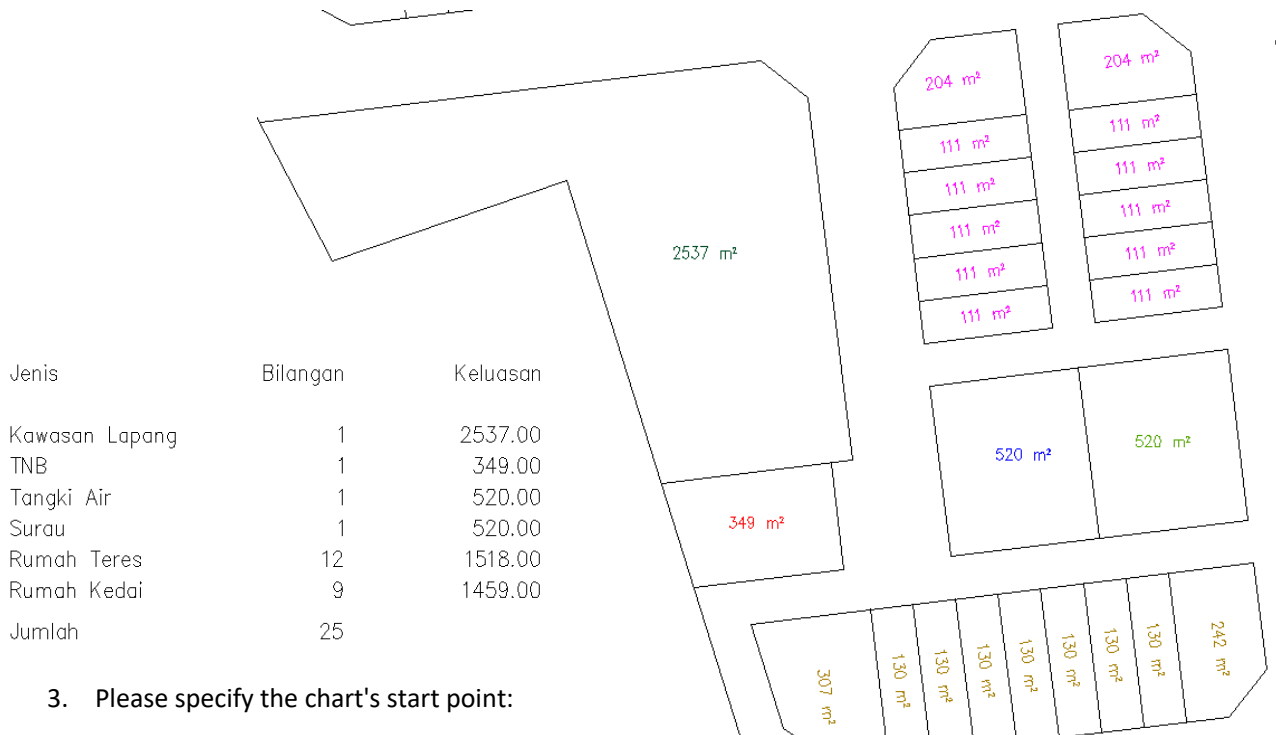

3. Please specify the chart's start point:
4. Please specify the total project area or skip: *Hit return* (See the above output as illustration)

Note:

Ensure all the area text are place in the correct Layer (refer to the right Red color dashed box) that you want to Include in your area table chart.

Status	Name	On	Freez	Lock	Color
☐	6325_BG_LOT_OU...	●	☼	🔒	white
☐	8540S_BG_BPOLY	●	☼	🔒	yellow
☐	Kawasan Lapang	●	☼	🔒	116
☐	Rumah Kedai	●	☼	🔒	42
☐	Rumah Teres	●	☼	🔒	magenta
☐	Surau	●	☼	🔒	72
☐	Tangki Air	●	☼	🔒	blue
☐	TNB	●	☼	🔒	red

23.(b) Shortline Brg Dist Table (v.18.6)

Function description: Auto create Bearing Distance table base on selected Lines

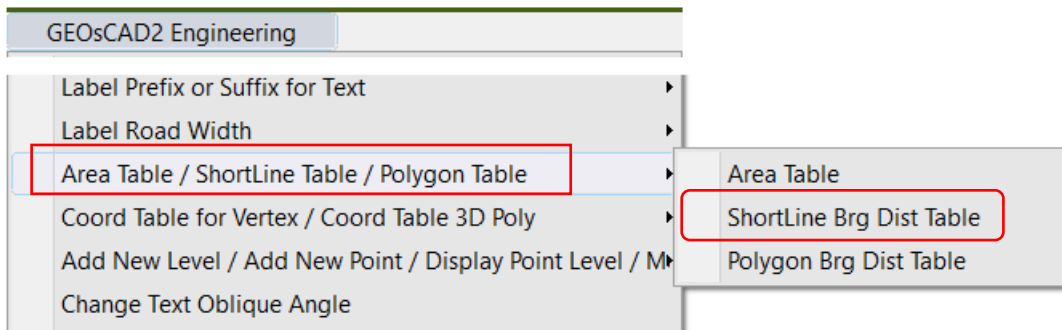

1. From GeoSCAD2 Engineering menu, choose [Area Table / ShortLine Brg Dist Table / Polygon Brg Dist table) → **Shortline Brg Dist Table**
2. Select objects (Lines) and then right click mouse button or press Enter to confirm selection
3. Please select a display point (Table location) or cancel:
4. Please enter new Line No <1> : **1**
5. Enter

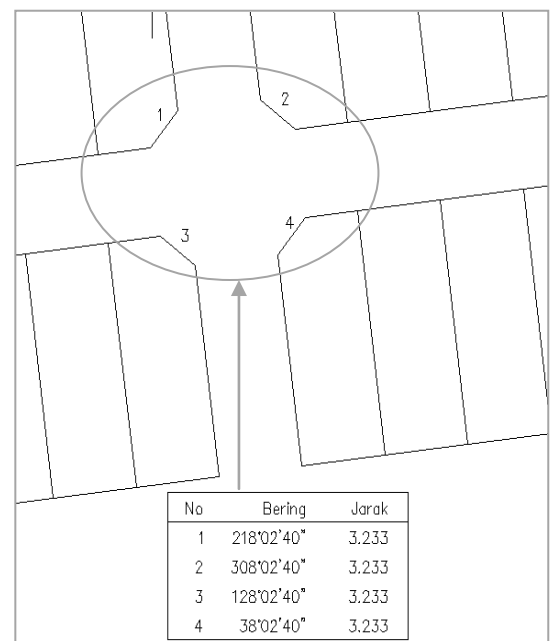
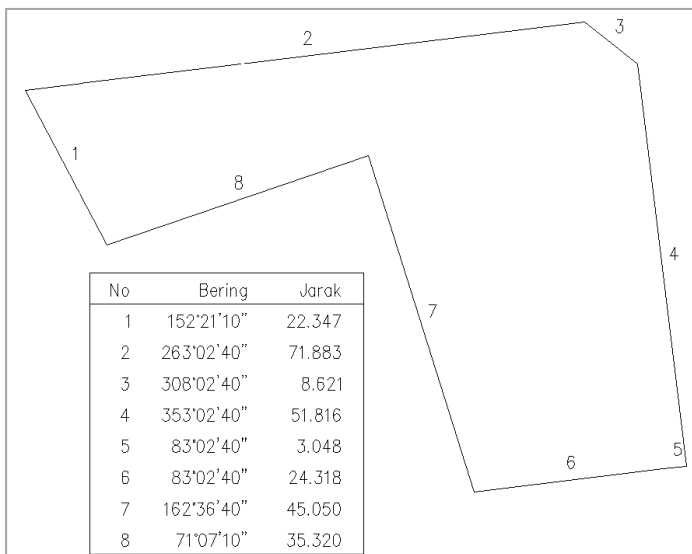

Note: Works with Line entity/object only.

23.(c) Polygon Brg Dist Table (v.18.6)

Function description: Auto create Bearing Distance table base on close Polygon

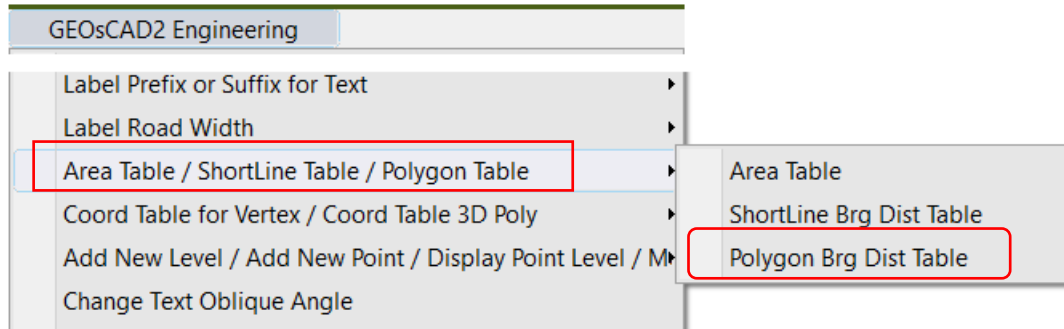

1. From GeoSCAD2 Engineering menu, choose [Area Table / ShortLine Brg Dist / Polygon Brg Dis Table]
→ **Polygon Brg Dist Table**
2. Set for AntiClockWise Key 2 : <1> : **1**
3. Please select a point: (Click on any location inside a close Polygon)
4. Pease enter new Line No <1> : **30**
5. Please select a display point (Table location) or cancel: refer to below illustration.

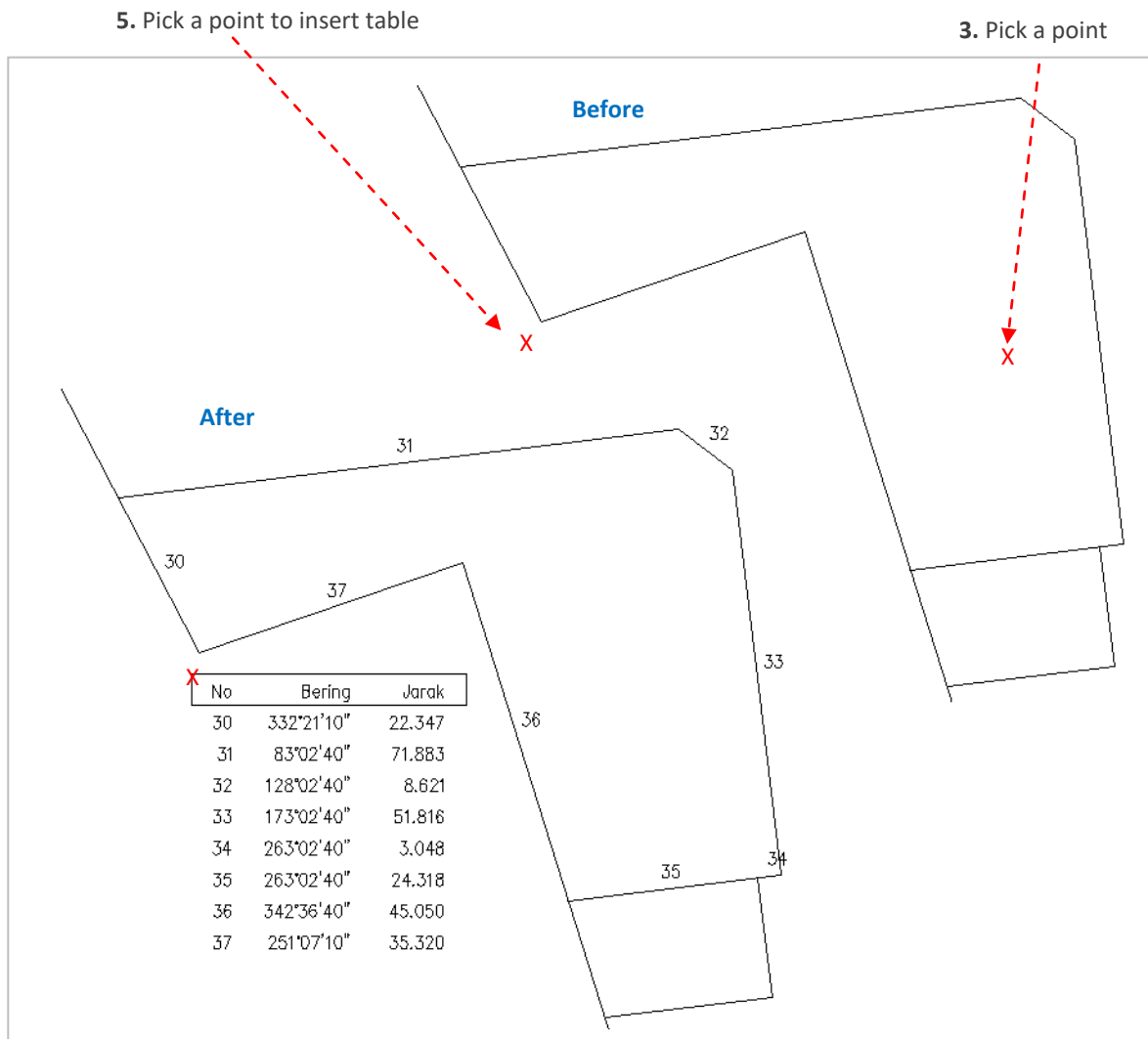

Function 23-1 : Table (Vertex / 3D Polyline Coordinates)

23.1.(a) Coordinate Table for Vertex

Function description: To create coordinate table base on selected pick points or 3D Polyline vertex

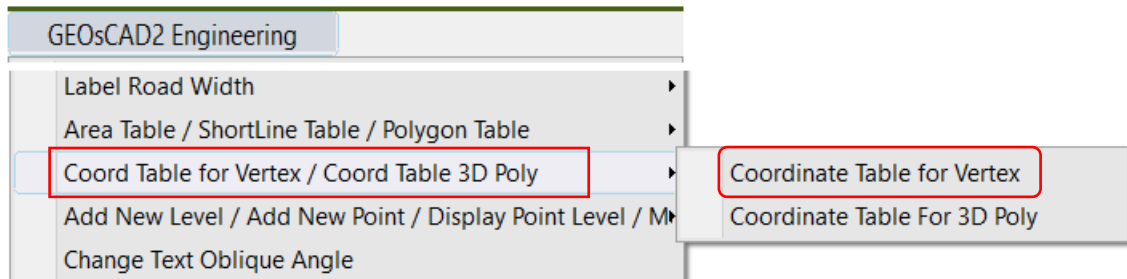

1. From GeoSCAD2 Engineering menu, choose [Coord Table for Vertex / Coord Table 3D Poly] → **Coordinate Table for Vertex**
2. Please select a display point (Table location) or cancel:
3. Please enter new Line / start No <1> : eg. **10**
4. Continue pick endpoint/center/intersect if have another coordinate points and press enter to Exit.

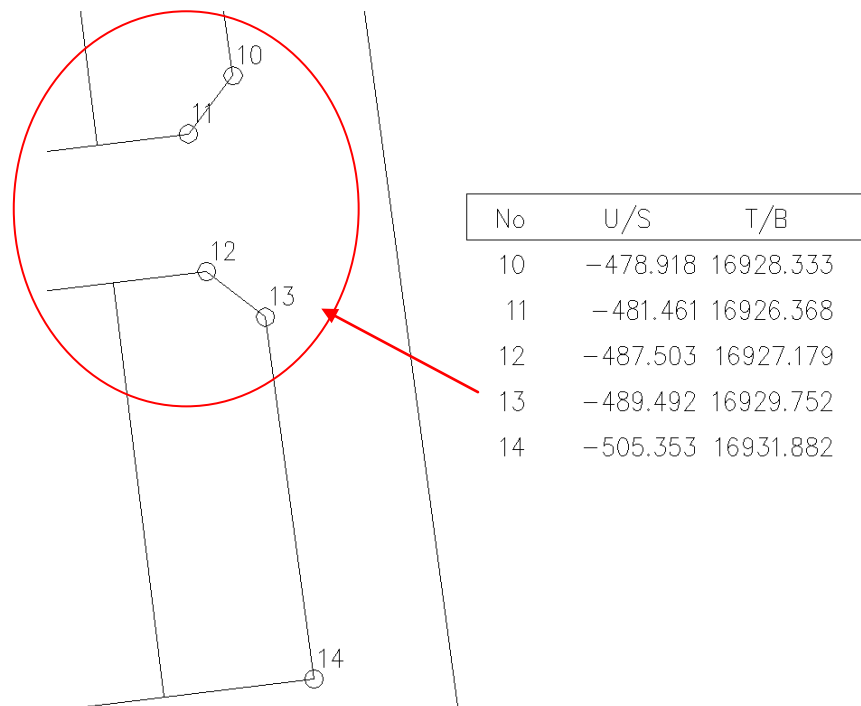

23.1.(b) Coordinate Table for 3D PolyLine (v.19)

Function description: To create coordinate table and ASCII file(*.txt) from 3D Polyline vertex

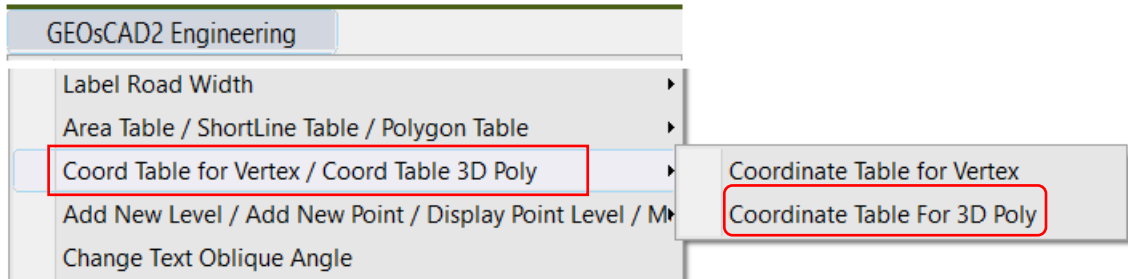

1. From GeoSCAD2 Engineering menu, choose [Coord Table for Vertex / Coord Table 3D Poly] → **Coordinate Table for Vertex**

Command: polycoord2

2. Select objects: (Select 3D Polyline)
You have selected 3D-Polyline
3. Enter new file name or enter for none: **Enter**
4. Please select a display point or cancel:
5. Please enter new Line No <1> : **1**
Export Ascii file to Drive C:\Geoscad2\3dpolyxyz.txt

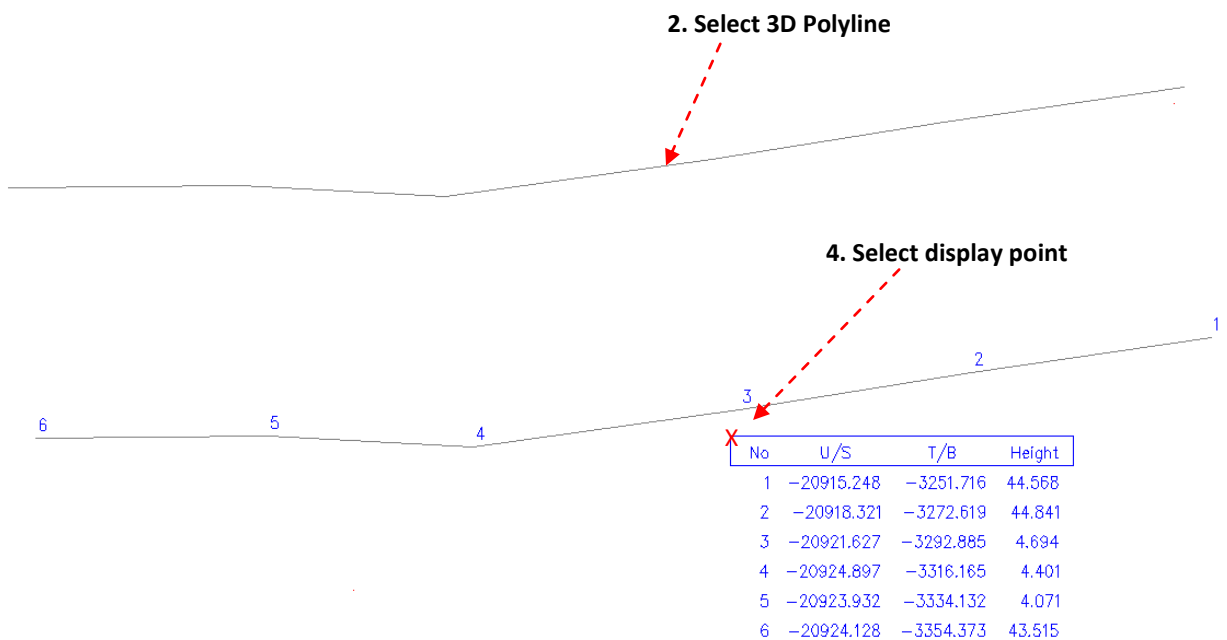

Function 24: Spot Level (Text & Points)

24.1 Add New Spot Level

Function description: To add new spot level (Text & 3D Point)

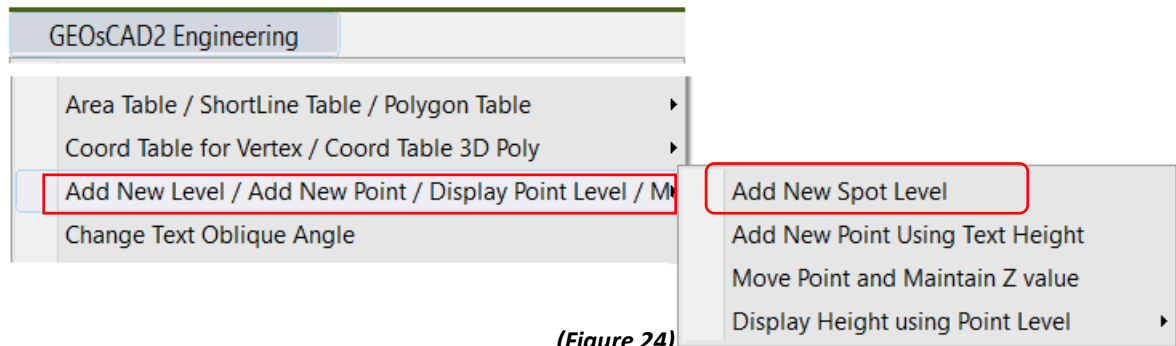

(Figure 24)

1. From GeoSCAD2 Engineering menu, choose [Add New Spot Level / Add New Point Using Spot Level / Display Point Level] (Refer Figure 24) ➤ **Add New Spot Level**
2. Please enter new decimal value <2> : **2**
3. Get new point (Pick a new point) :
4. Enter new spot level: **42.45**
5. Get new point (Pick a new point) :
6. Enter new spot level: **42.30**
7. Repeat step 3 to continue and press Esc to cancel.
8. Example :



24.2 Add New Point Using Spot Level (v18.6)

Function description: To create 3D points object or entity base on Text value.

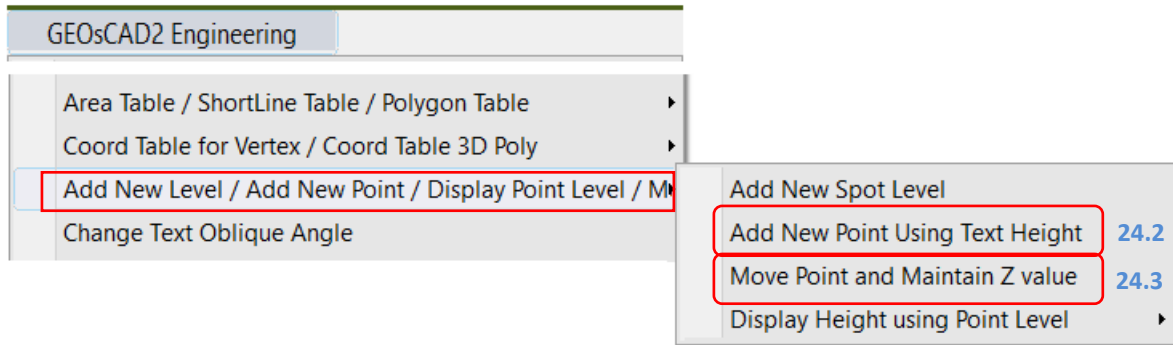

1. From GeoSCAD2 Engineering menu, choose [Add New Spot Level / Add New Point Using Spot Level / Display Point Level] ➤ **Add New Point Using Text Height / Spot Level**
2. Select objects (Select all text)

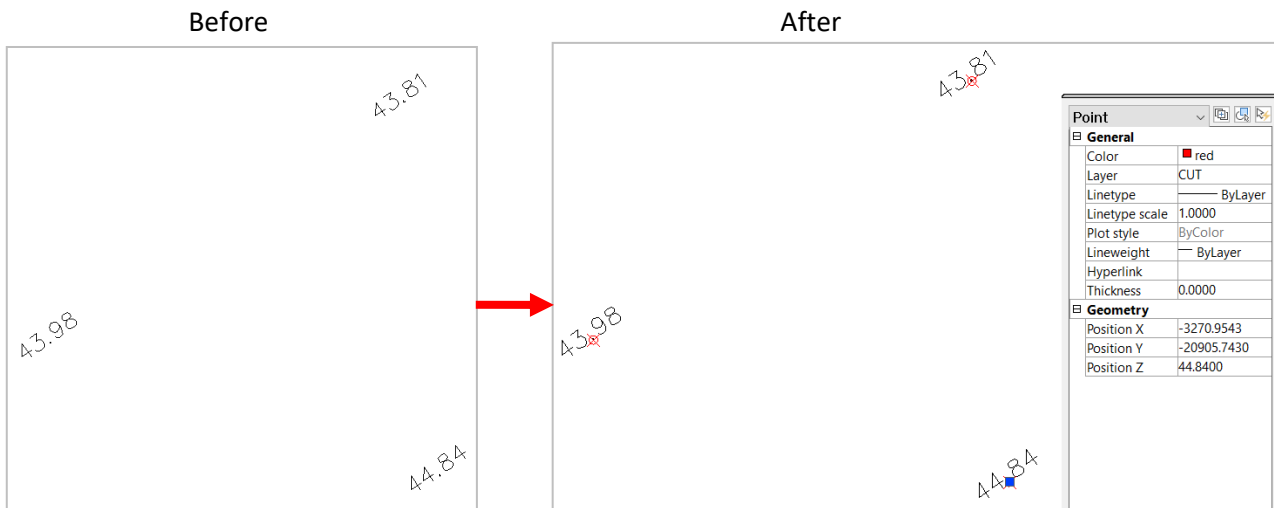

24.3 Move 3D Point and Maintain Z value (v.19)

1. From GeoSCAD2 Engineering menu, choose [Add New Spot Level / Add New Point Using Spot Level / Display Point Level] ➤ **Move Point and Maintain Z value**
2. Select objects (Select Points)

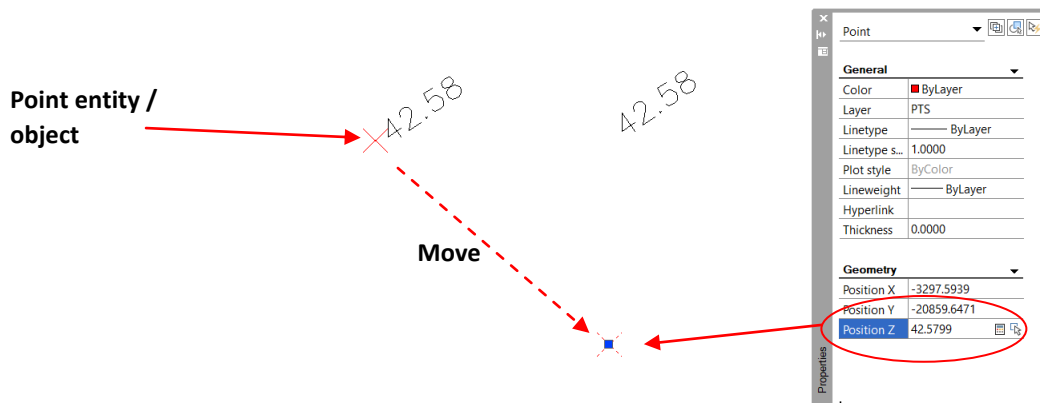

24.4 Display Height Using Spot Level (v.18.6)

Function description: Automatic generate Text Level object or entity base on existing 3D points.

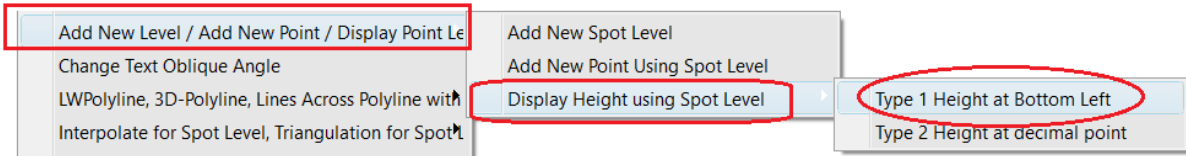

1. From GeoSCAD2 Engineering menu, choose [Add New Spot Level / Add New Point Using Spot Level / Display Point Level] ➤ **Display Height using Spot Level** ➔ **Type 1 Height at Bottom Left**
2. Please enter new decimal value <2> : **2**
3. Please enter new text rotation angle <90> : **45**
4. Select Point objects one at a time follow by **Enter** or by 2-point **Window**

Example : **Type 1 Height at Bottom Left**

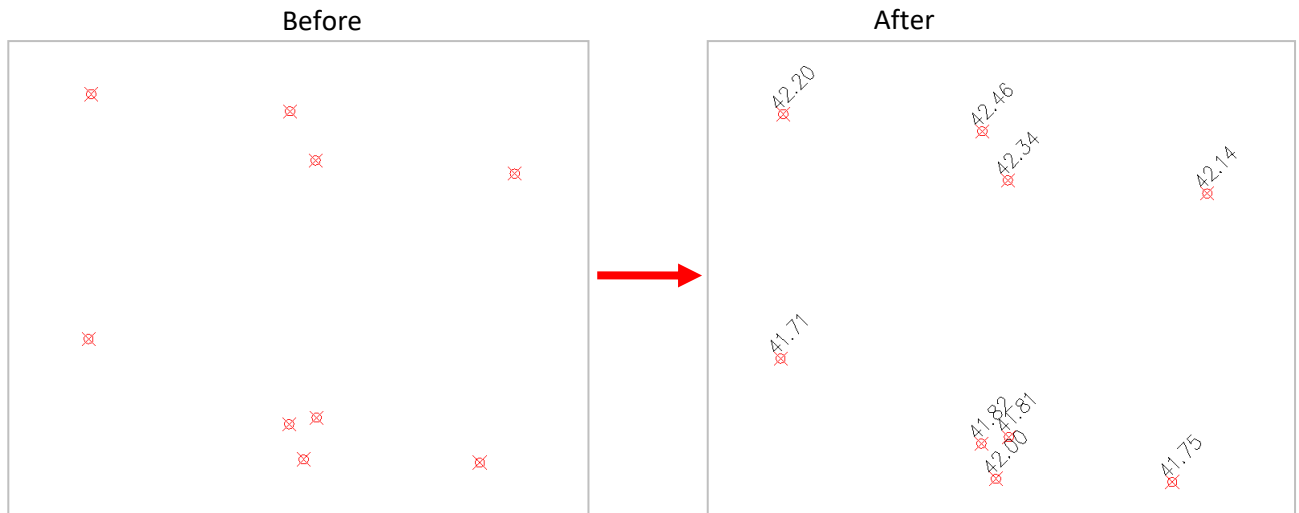

Example : **Type 2 Height at decimal point**

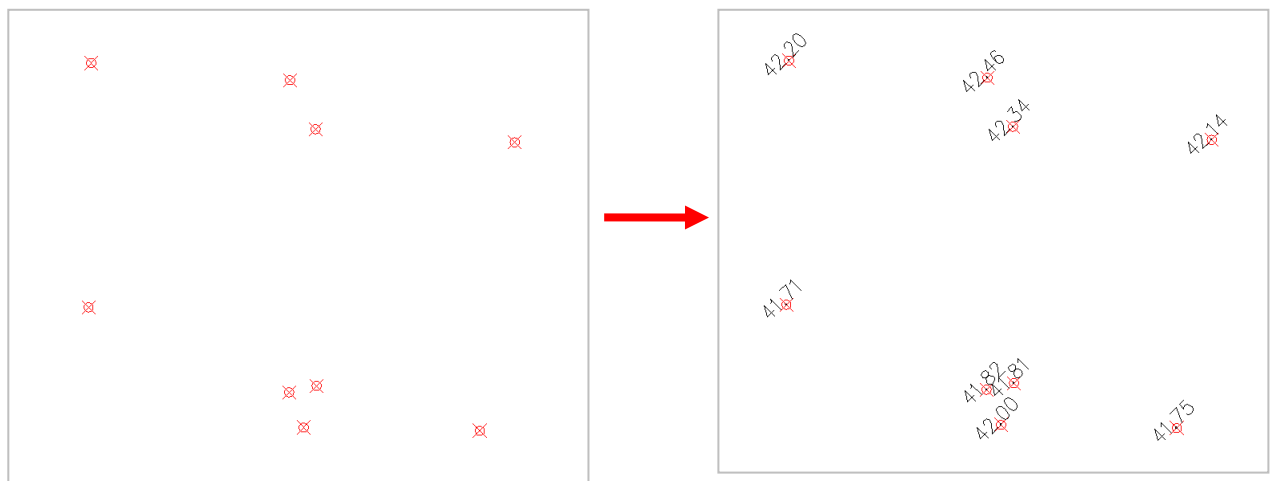

Function 25: Change Text Oblique Angle

Function description: Change Text Oblique Angle

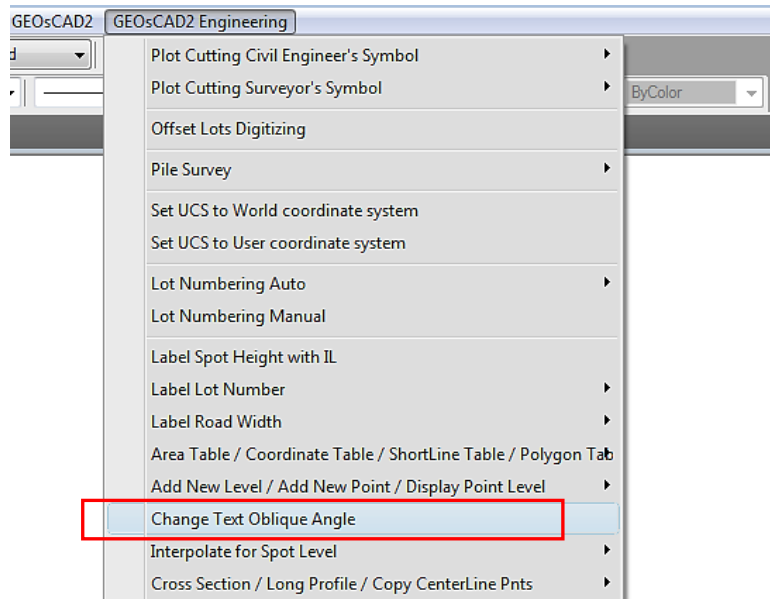

(Figure 25.)

1. From GeoSCAD2 Engineering menu, choose [**Change Text Oblique Angle**]
2. *Select Text objects one at a time follow by **Enter** or by 2-point **Window***

Example :

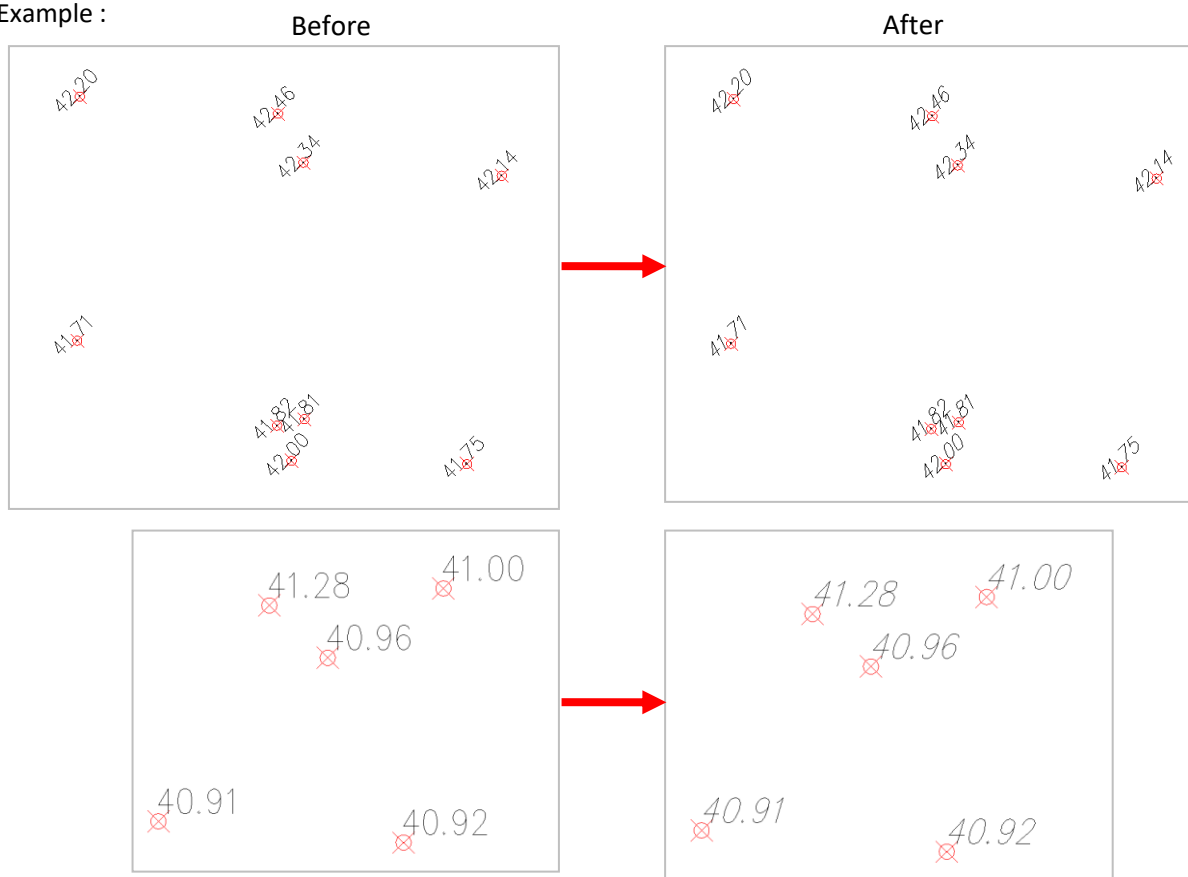

Function 25-1 : LWPolyline , 3D-Polyline, Line Across Polyline with points.

25.1.(a) Add Points LWPolyline (v.19)

Function description: Automatic Add Points on LWPolyline vertex

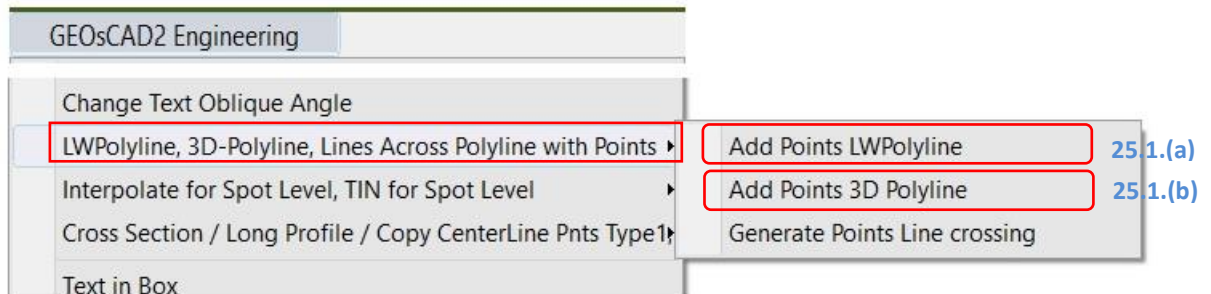

1. [LWPolyline, 3D-Polyline, Lines Across Polyline with Points] → **Add Points LWPolyline**
2. Select LWPolyline follow by **Enter**

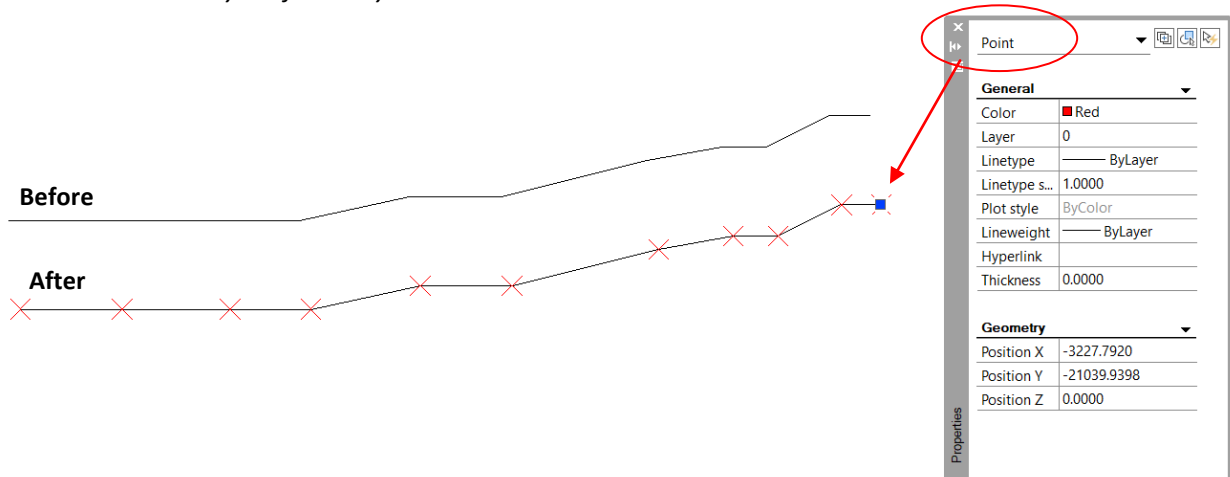

25.1.(b) Add Points 3D Polyline (v.19)

Function description: Automatic Add Points on 3D Polyline vertex

1. [LWPolyline, 3D-Polyline, Lines Across Polyline with Points] → **Add Points 3D Polyline**
2. Select 3D Polyline follow by **Enter**

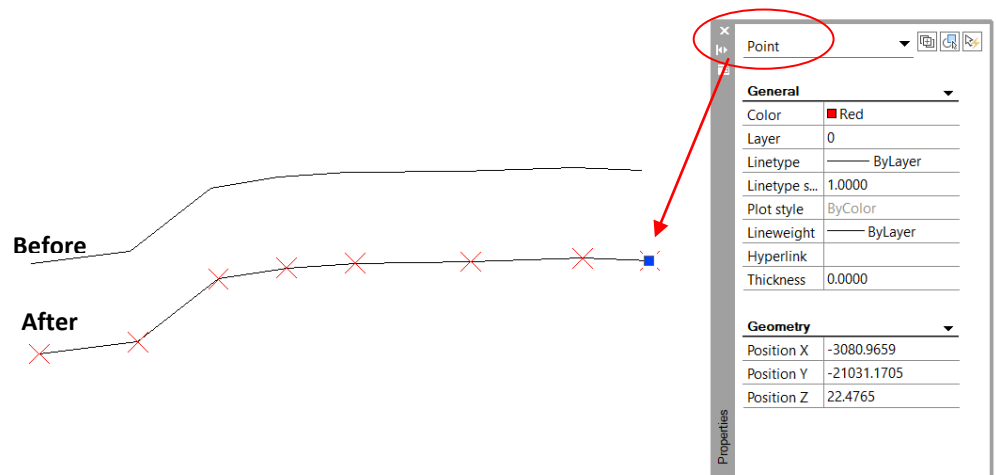

25.1.(c) Add Points 3D Polyline (v.19)

Function description: Automatic Generate Points intersect Line crossing

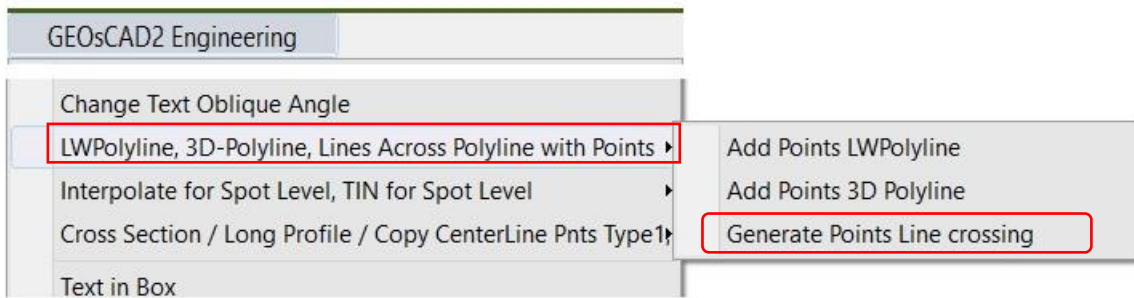

1. [LWPolyline, 3D-Polyline, Lines Across Polyline with Points] → **Generate Points Line crossing**
2. Select Line follow by **Enter**

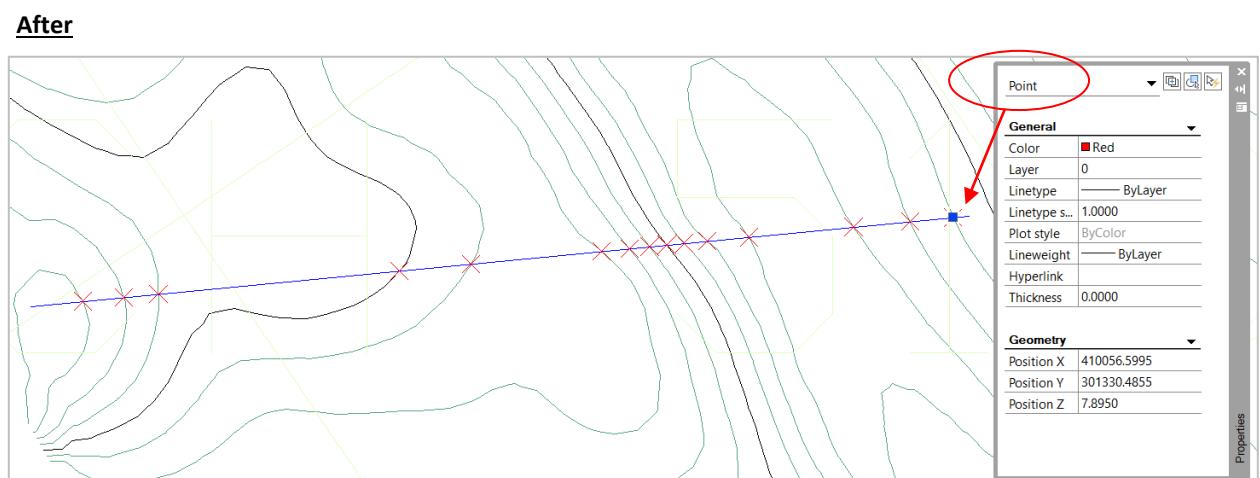
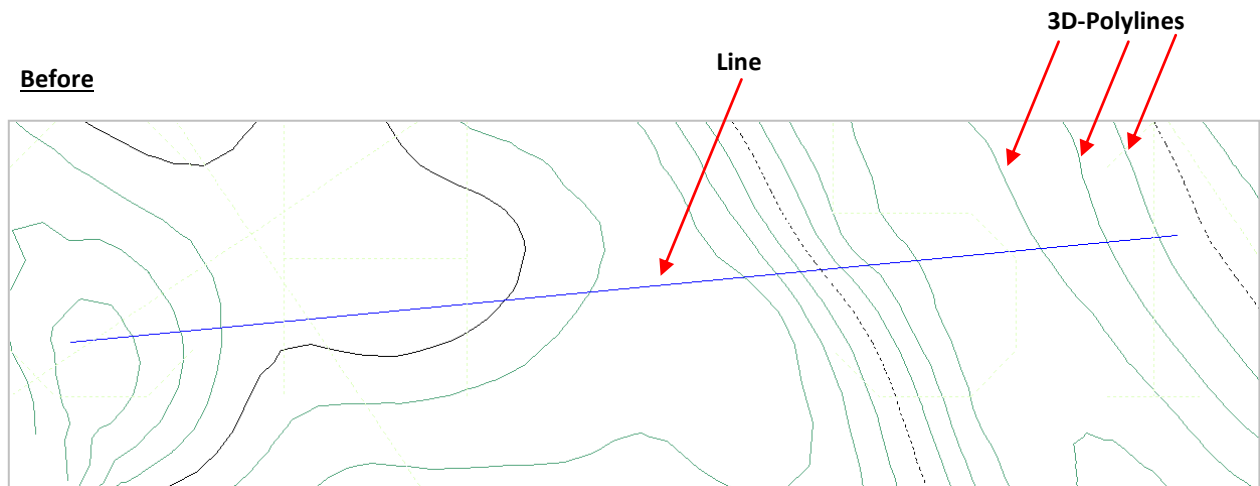

Function 26: Interpolation (Spot Level, Cross Section & 3D Model)

26.1 Interpolate Spot Level

Function description: Interpolate Spot Level(Text and 3D point) base on 2 reference Point.

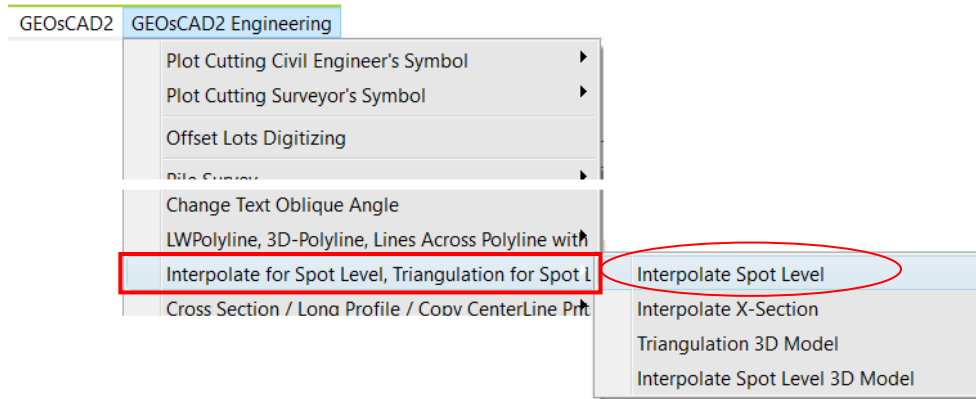

1. GeoSCAD2 Engineering menu, choose [Interpolate for Spot Level] > *Interpolate Spot Level*
2. Please enter new decimal value <2> : **2**
3. Select 2 Spot Level (Text Level or Point)
 - eg. Any of the combination: A & B / D & A / A & B / B & C (refer image 24.1a)
4. Pick point between 2 selected reference point
5. Repeat step 4 to continue and press Enter to exit.

Image 26.1a

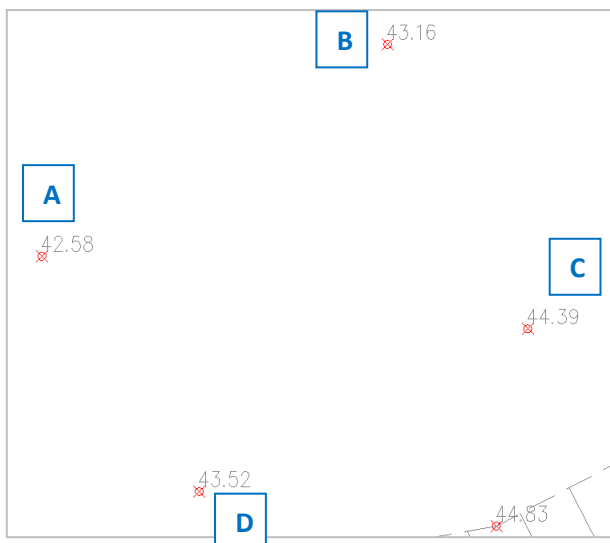
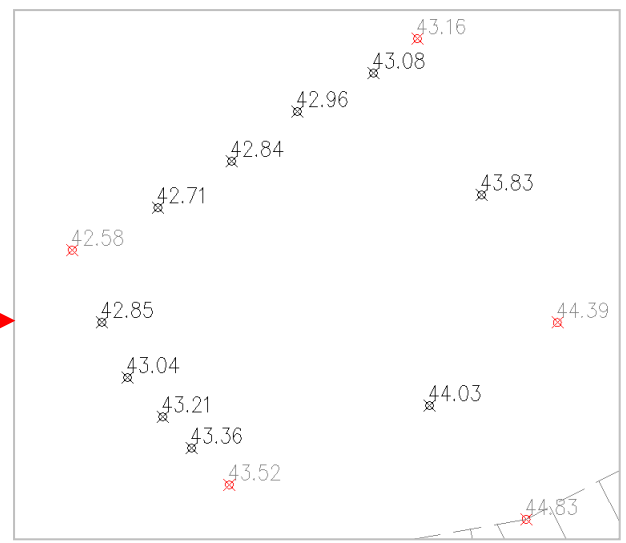
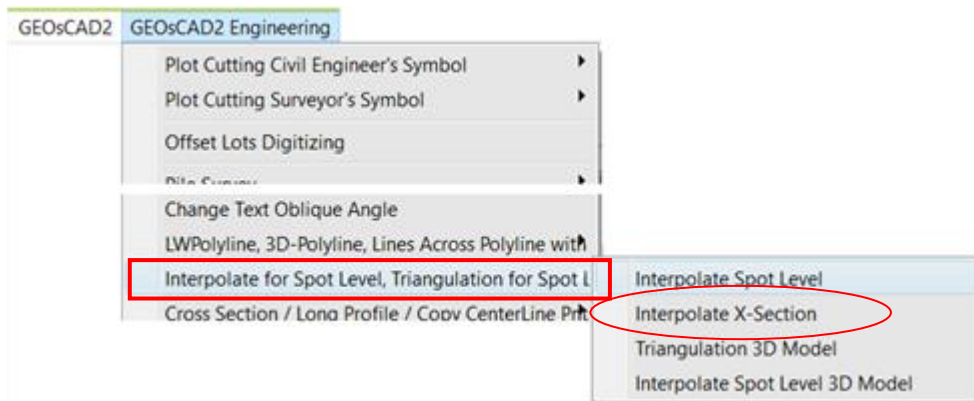

Image 26.1b– Result after interpolation



26.2 Interpolate Cross Section

Function description: Interpolate Cross Section



1. GeoSCAD2 Engineering menu, choose [Interpolate for Spot Level] > *Interpolate X-Section*
2. Please enter new decimal value <2> : **2**
3. Select 2 Spot Level (Text Level or Point)
 - eg. Pick / select Text or Point from Line **A** then Line **B** (refer image 24.2a)
4. Pick on the Line object (New cross Section Line **C**)
5. Repeat step 4 to continue and press Enter to exit.

Image 26.2a

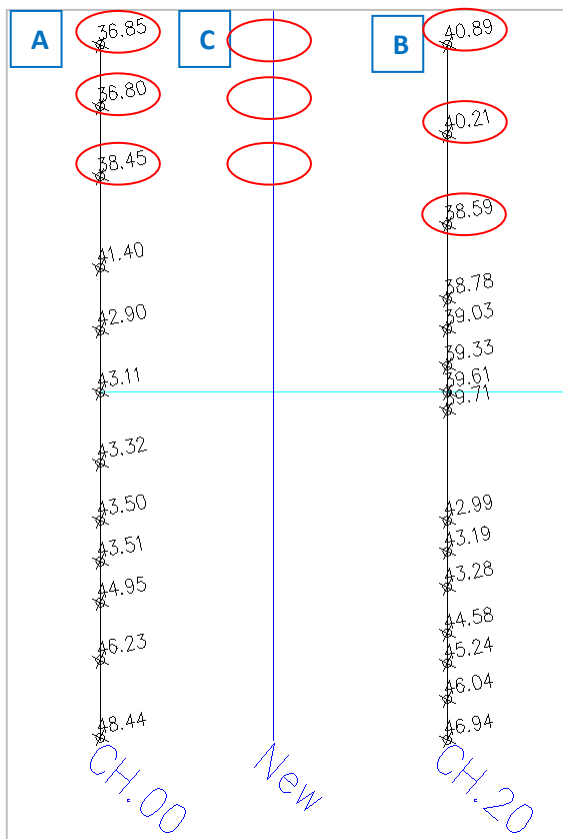
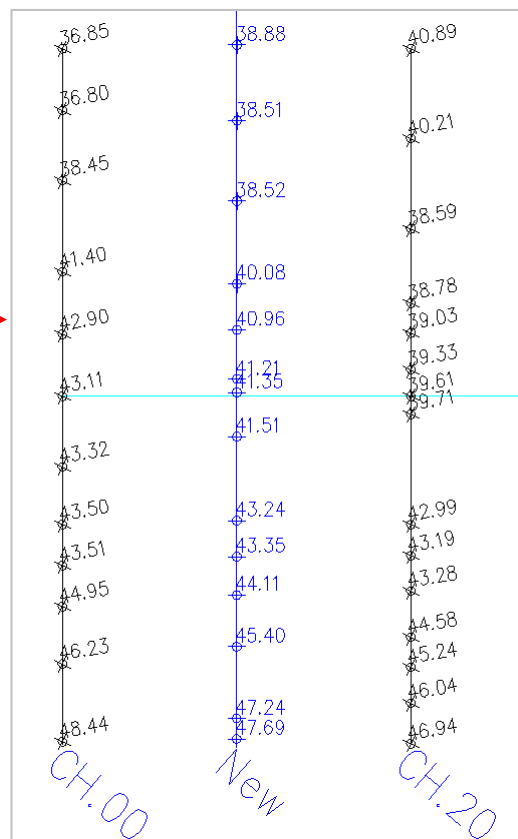
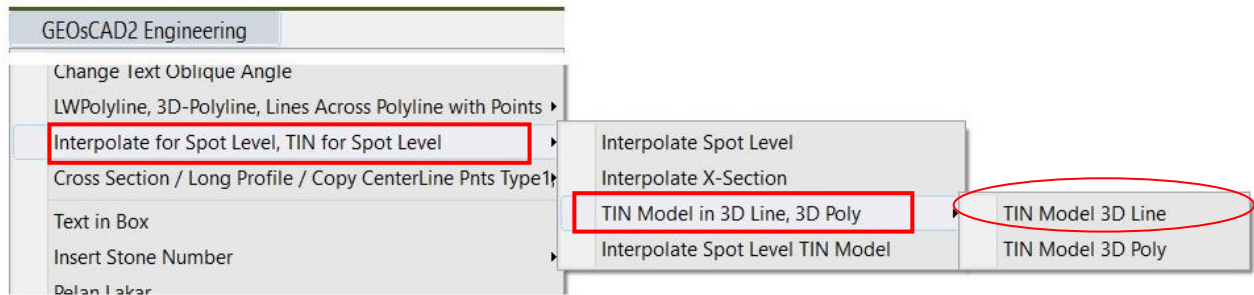

Image 26.2b – Result after interpolation



26.3.(a) TIN Model 3D Line (v.18.6)

Function description: Generate 3D Triangulation Model using Line from 3D Points



1. From menu, choose [Interpolate for Spot Level, TIN for Spot Level] ➤ [TIN Model in 3D Line, 3D Poly] ➤ *TIN Model 3D Line*
2. Select all Points or selected require of Points, hit **Enter** once to Preview result
3. Repeat step 2 to add more Points and to proceed to generate TIN hit Enter Twice or Enter right after Preview mode.

Before – Drawing consist of 3D Points

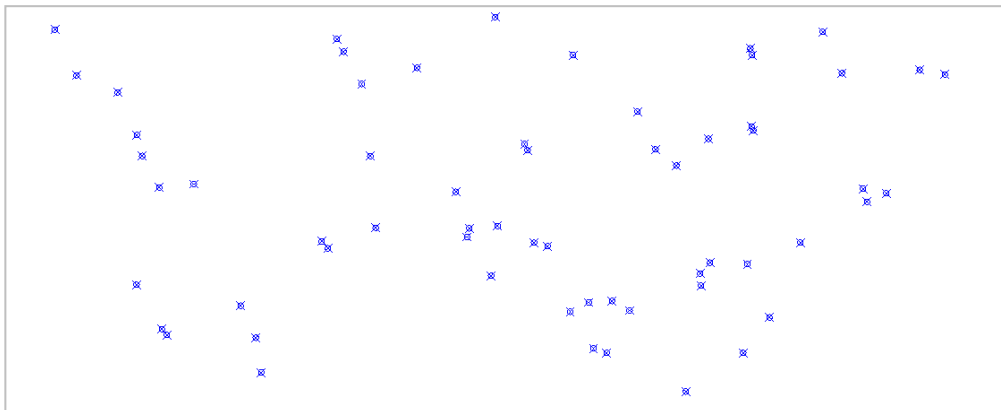

After – Triangulations Result

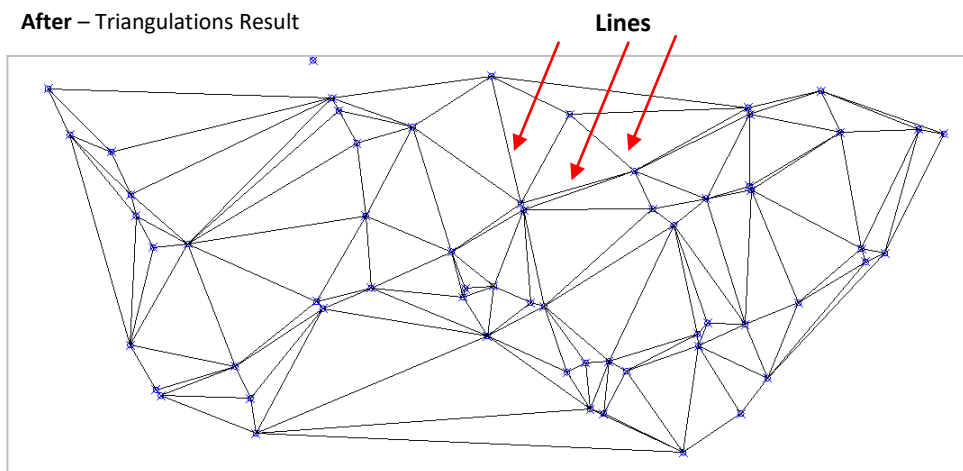

26.3(b) TIN Model 3D Polygon (v.19 Pro)

Function description: Generate 3D Triangulation Model using 3D Polygon from 3D Points

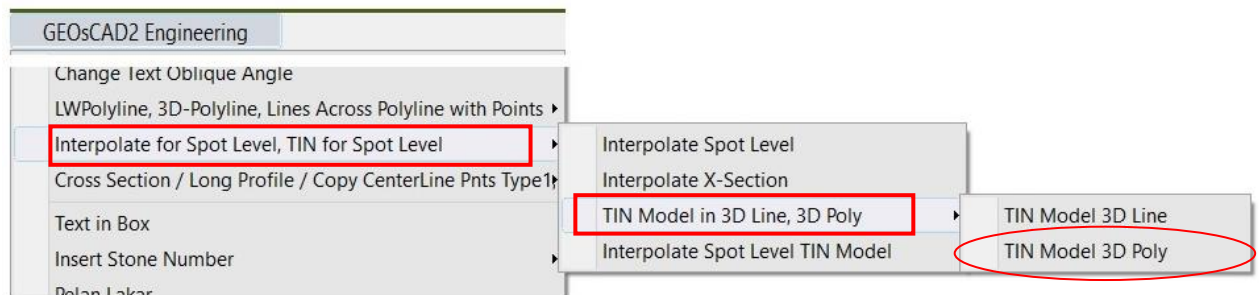

1. From menu, choose [Interpolate for Spot Level, TIN for Spot Level] > [TIN Model in 3D Line, 3D Poly] > *TIN Model 3D Poly*
2. Select all Points or selected require of Points, hit **Enter** once to Preview result
3. Repeat step 2 to add more Points and to proceed to generate TIN hit Enter Twice or Enter right after Preview mode.

Before – Drawing consist of 3D Points

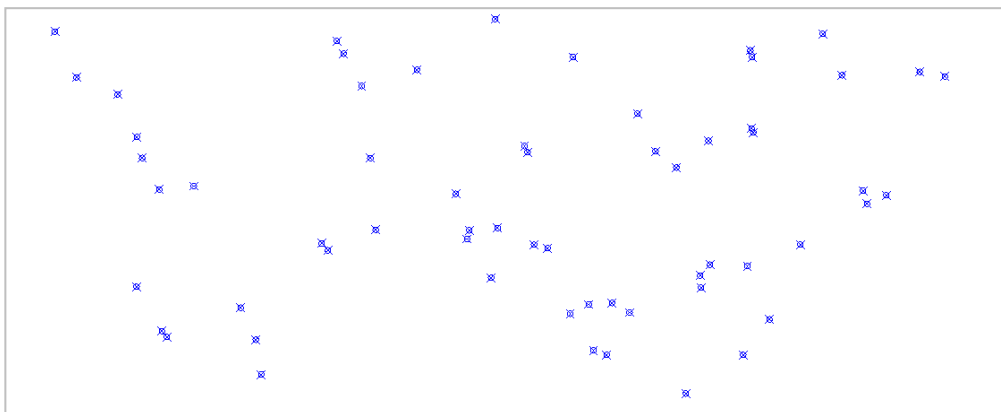

After – Triangulations Result

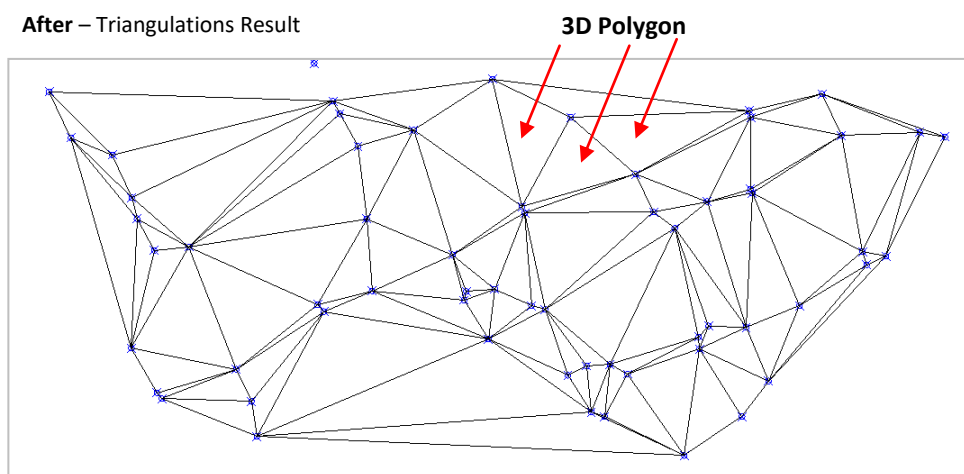

26.4 Interpolate Spot Level 3D Model (v.18.6)

Function description: Auto Generate 3D Points from intersection between Line and the 3D Triangulation Model.

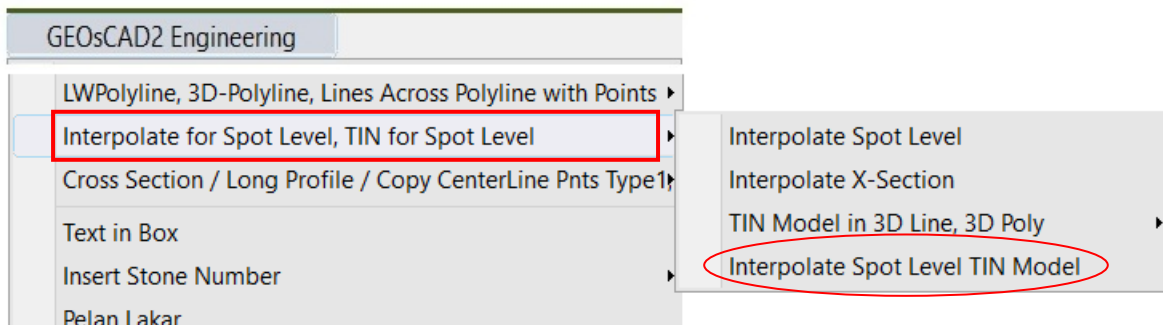

1. Draw a new Line across the Triangulation Model

2. From menu, choose [Interpolate for Spot Level, TIN for Spot Level] > *Interpolate Spot TIN Model*

3. Select the new Line follow by Enter.

Before

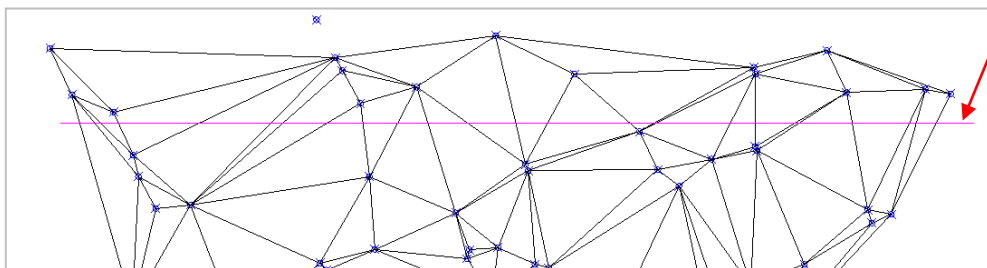

After – Result of the Interpolation.

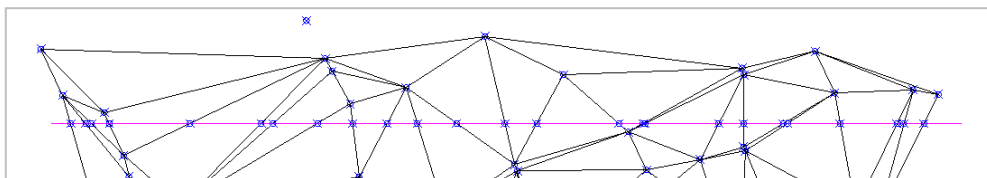

4. TRIM Line edge before proceed to generate Cross Section. (Refer to below image)

After – Result after Trim

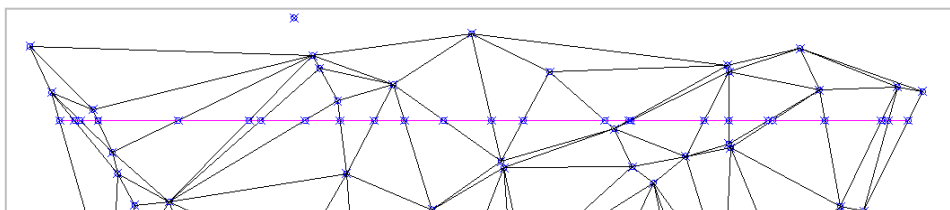

Function 27: Cross Section / Long Profile / Copy CenterLine Points

27.1 (a) Cross Section – X-Section Text Rotate 180Deg – Datum Auto (Updated v.21)

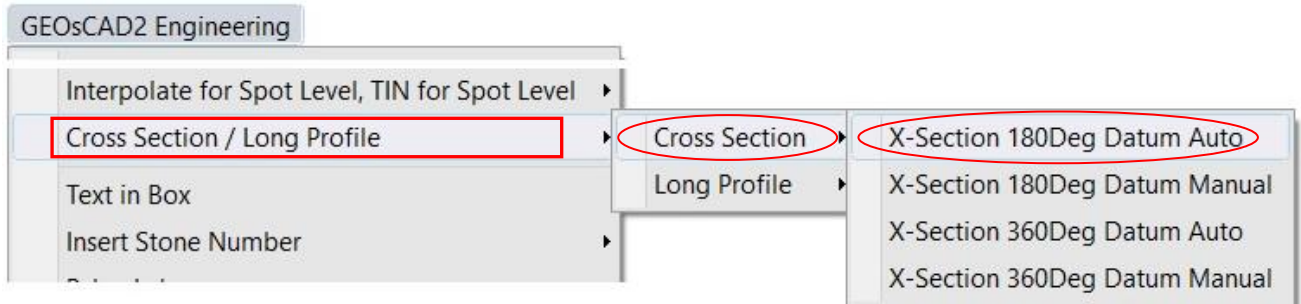

1. Select **Cross Section** → **X-Section 180Deg Datum Auto**.
Refer to *command prompt* area for the following user input.
2. Please enter new decimal value <2> : **2**
3. Enter New X-Section Horizontal Scale or enter for none: <200> : **Enter** / key in new scale
4. Enter New X-Section Vertical Scale or enter for none: <200> : **Enter** / key in new scale
5. Enter X-Section Chainage value or Enter for Default: <0> : **0**
6. Enter X-Section Interval value or Enter for Default: <0> : **20**
7. Enter X-Section Datum INDEX value or enter for none: <2> : **3**
8. Select object (Cross Section Line) :
9. Select X-section Centerline or enter for none:
10. Please select a display point or cancel:

Note: Off all not related Layers except for the Spot Level Text, Points & Cross Section Lines.

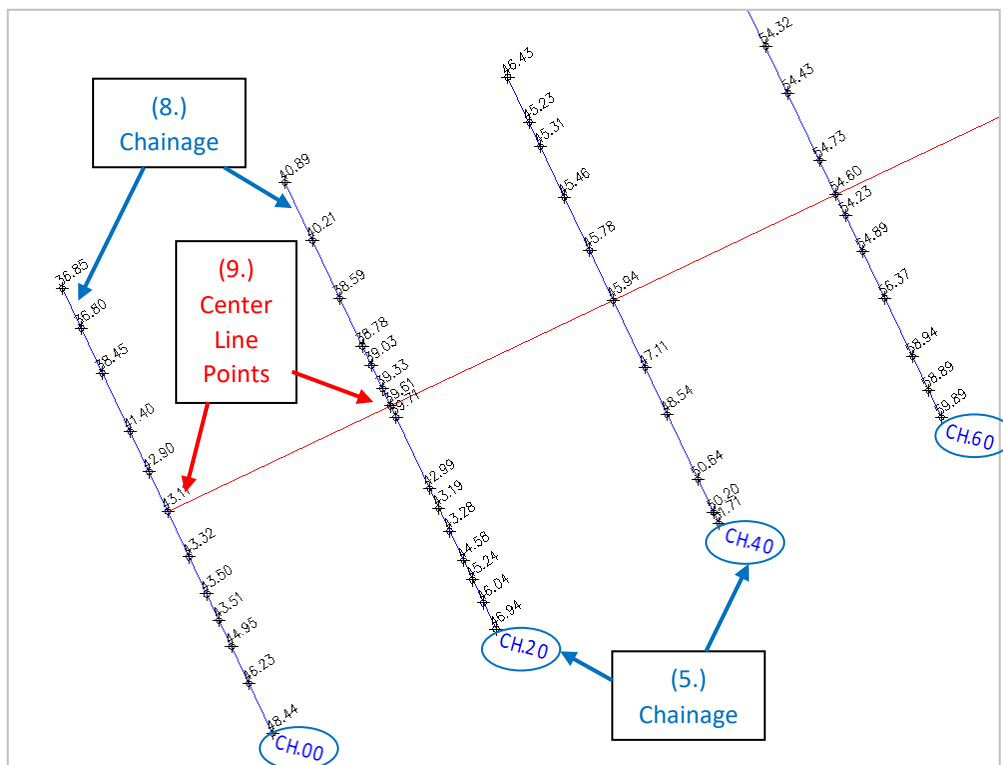

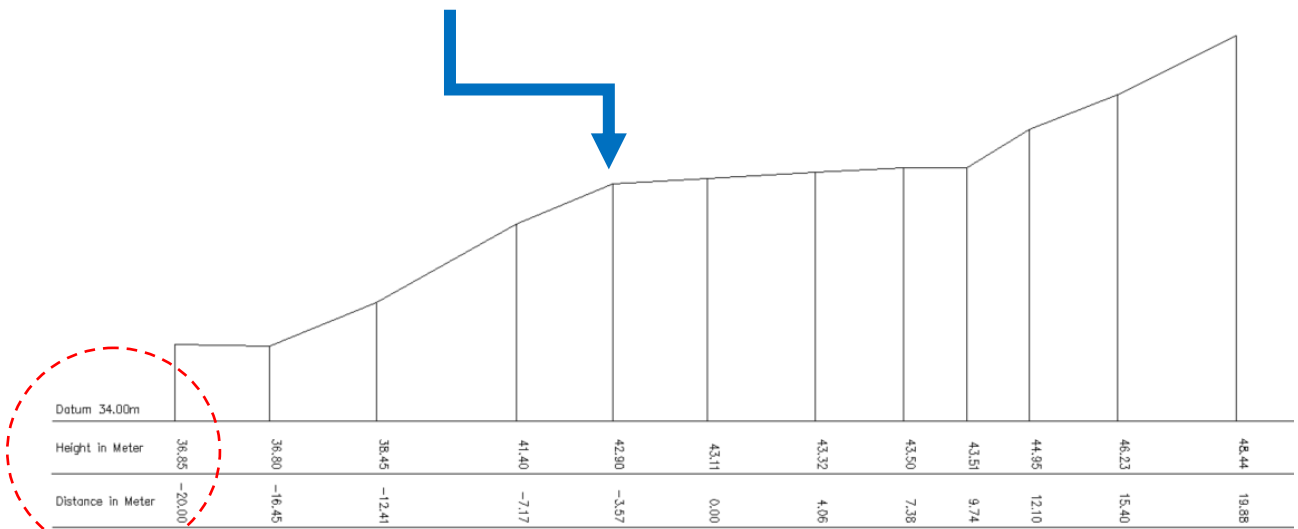
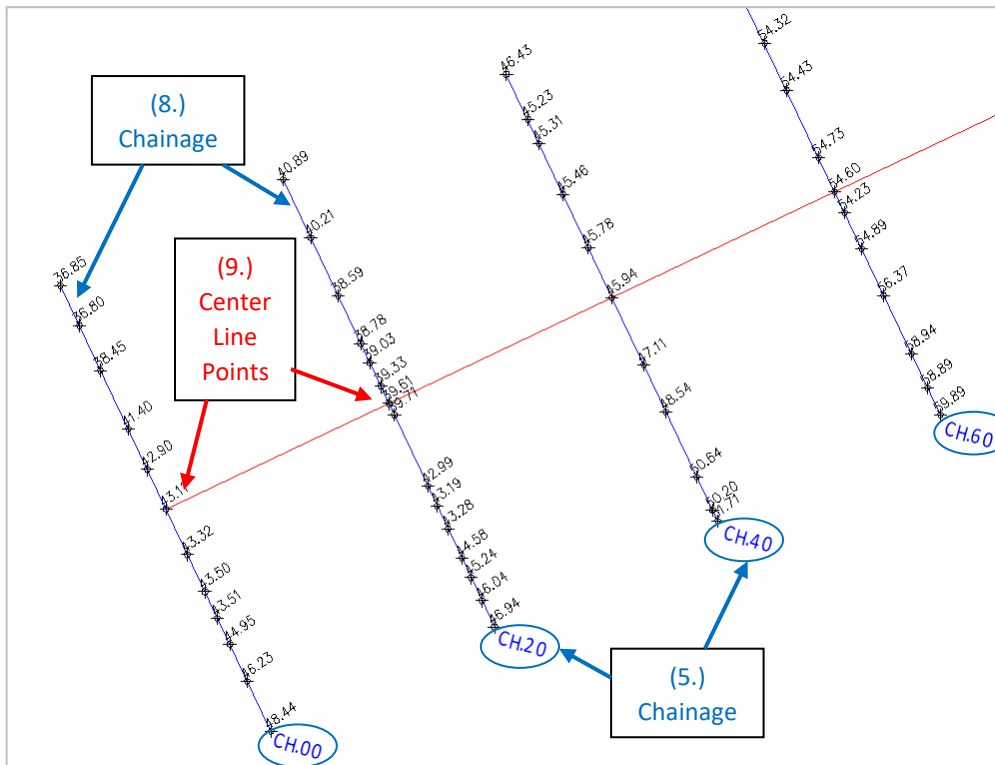

GROSS SECTION CH 0
 VERTICAL: 1:200.00
 HORIZONTAL: 1:200.00

Datum	34.00m
Height in Meter	36.85
Distance in Meter	-20.00

Notes - Auto Datum :

Software will automatic calculate datum height and return **nearest to an Integer number** base on below formula.

Datum = Lowest Height point - <User key in datum value> eg. (34.00 = 36.85 - 3)

27.1(b) Cross Section : X-Section Text Rotate 180Deg -Datum Manual (Updated v.21)

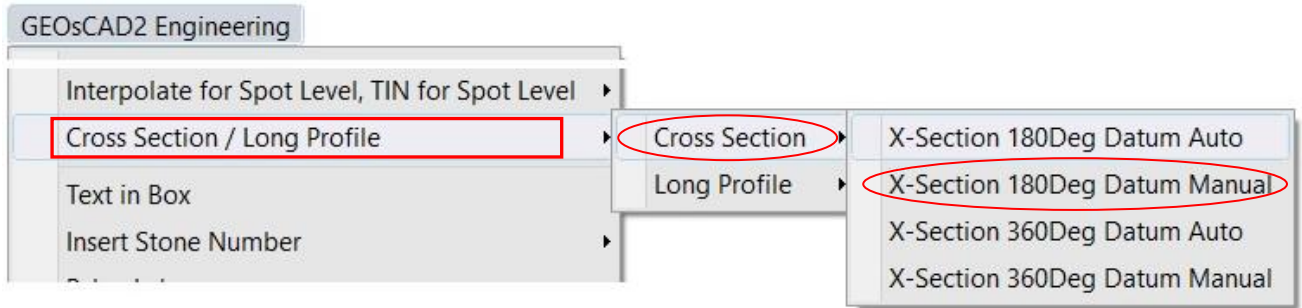

1. Select **Cross Section** → **X-Section 180Deg Datum Manual**.
Refer to command prompt area for the following user input.
2. Please enter new decimal value <2> : **2**
3. Enter New X-Section Horizontal Scale or enter for none: <200> : **Enter** / key in new scale
4. Enter New X-Section Vertical Scale or enter for none: <200> : **Enter** / key in new scale
5. Enter X-Section Chainage value or Enter for Default: <0> : **0**
6. Enter X-Section Interval value or Enter for Default: <0> : **20**
7. Select object (Cross Section Line) :
8. Select X-section Centerline or enter for none:
9. Please select a display point or cancel:
10. Enter X-Section Datum value or enter for none: <0> : **34**

Note: Off all not related Layers except for the Spot Level Text, Points & Cross Section Lines.

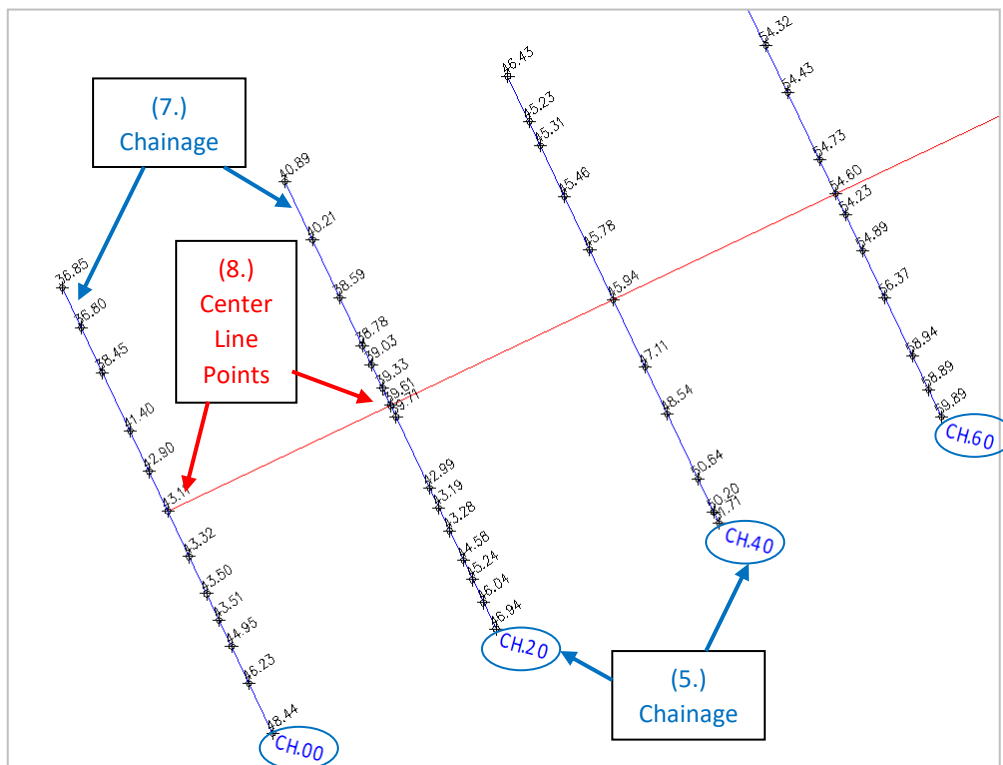

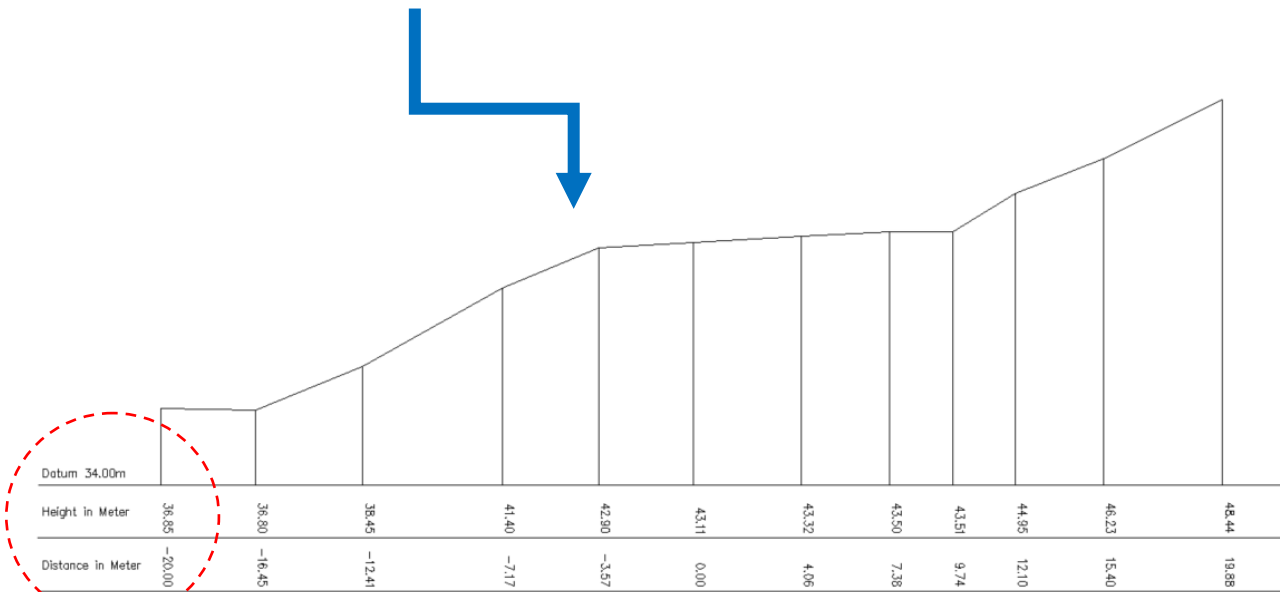
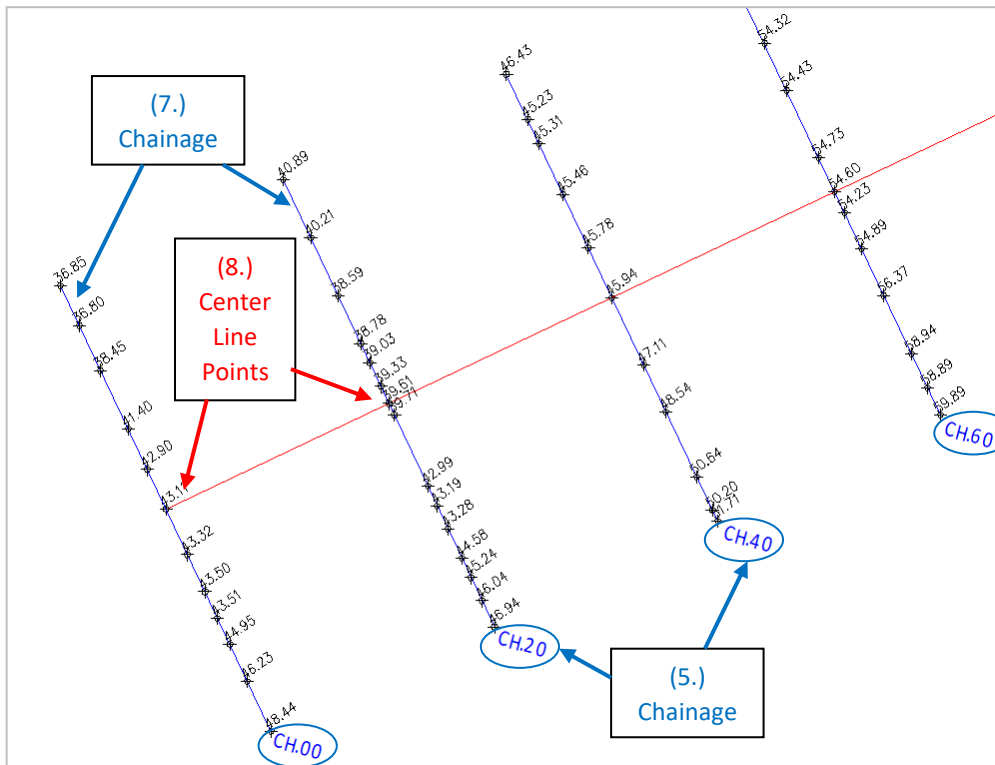

CROSS SECTION CH 0
 VERTICAL: 1:200.00
 HORIZONTAL: 1:200.00

Datum	34.00m
Height in Meter	36.85
Distance in Meter	-20.00

27.2 Long Profile – Long Profile Text Rotate Angle 180Deg (Updated v.21)

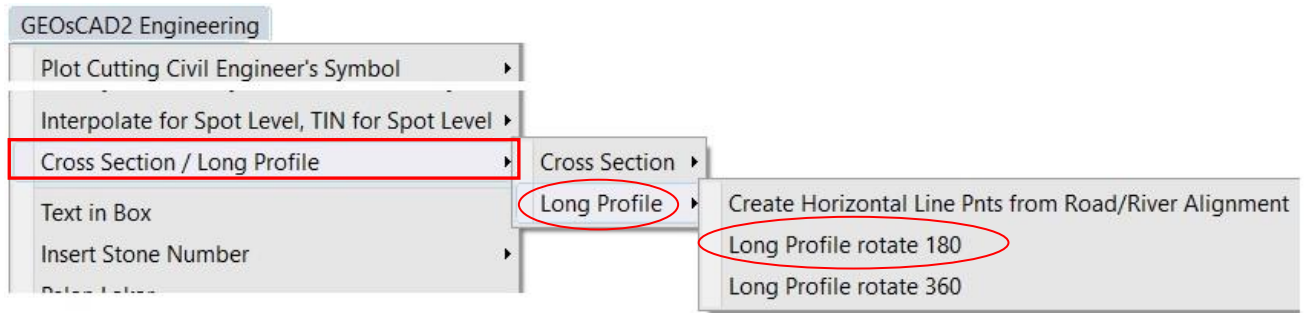

1. Select **Long Profile** → **Long Profile rotate 180**.
Refer to command prompt area for the following user input.
2. Please enter new decimal value <2> : **2**
3. Enter New Long Profile Horizontal Scale or enter for none: <1000> : **1000**
4. Enter New Long Profile Vertical Scale or enter for none: <100> : **100**
5. Enter Long Profile Datum value or enter for none: <2> : **2**
6. Select Long Profile line .. **Select Long Profile line/object**
7. Select Long Profile Chainage or enter for none: .. **Select Start Chainage**
8. Please select a display point or cancel: ... **Select start point to draw**

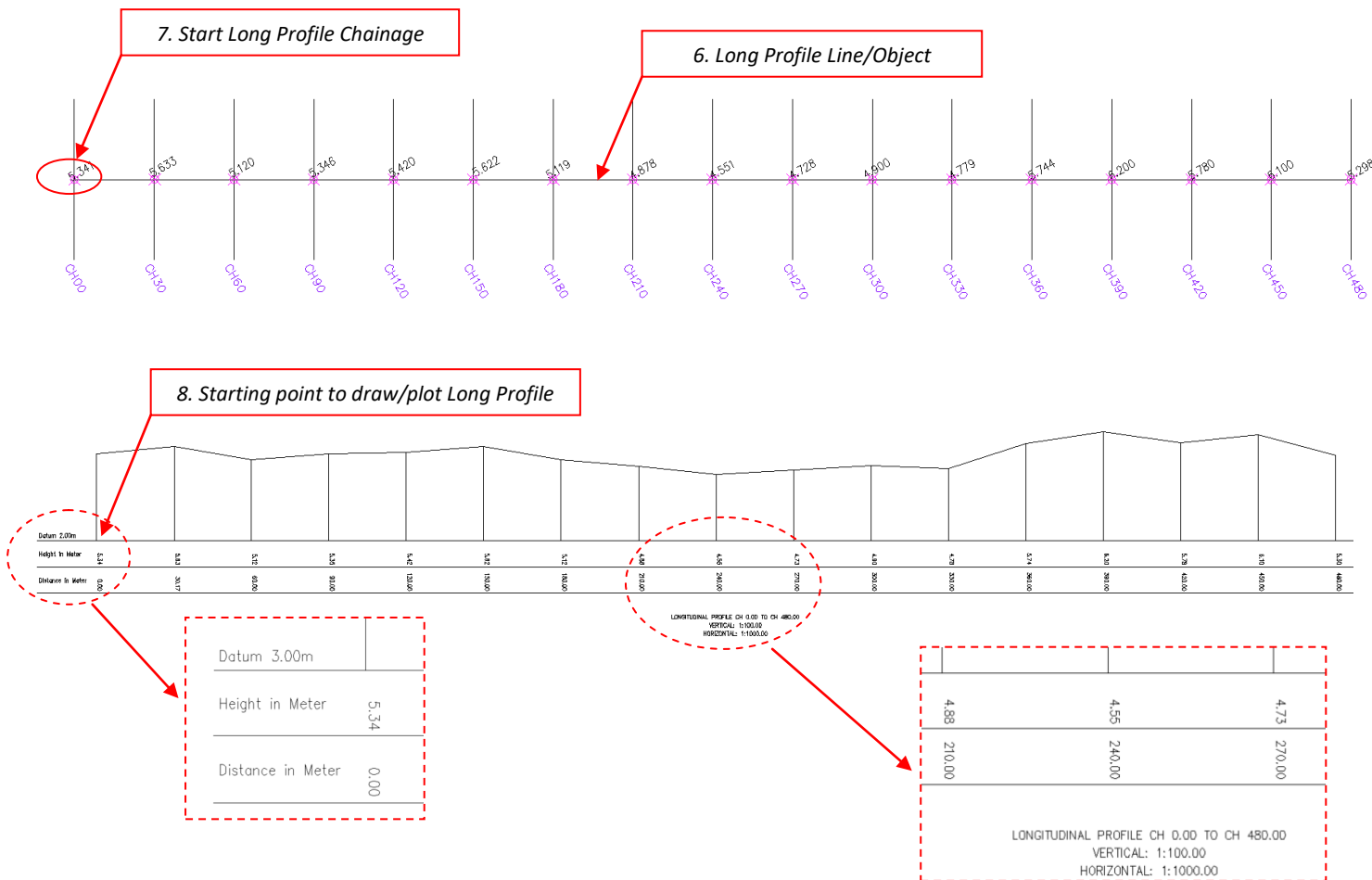

Note – Auto Datum:

Software will automatic calculate datum height and return **nearest to an Integer number** base on below formula.

Datum = Lowest Height point - <User key in datum value> eg. (3.00 = 4.55 - 2)

27.3 Create Horizontal Line Points From Road/River Alignment (Updated v.21)

Function description: Generate a line draw across 3D points from a polyline and 3D points underlay.

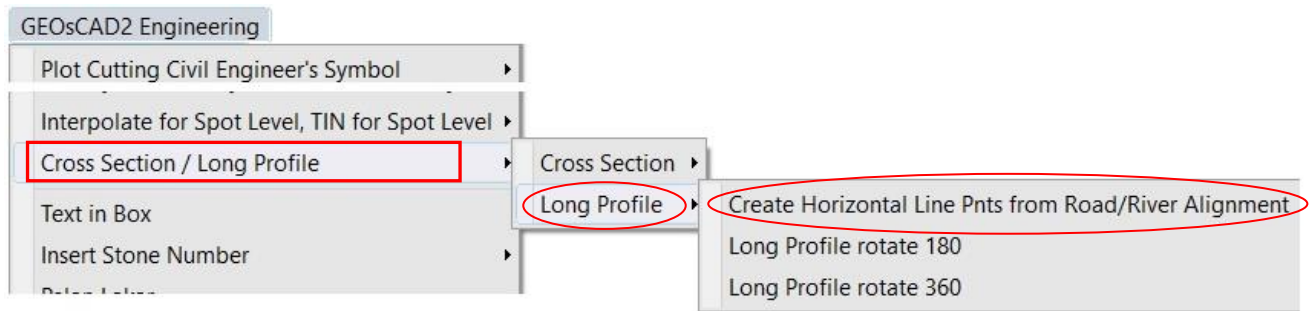

Steps:

1. Select **Create Horizontal Line Points From Road/River Alignment**
2. Select a display point or cancel: (Refer to **Point A**)
3. Select objects: **Select Polyline follow by enter / space bar** (Refer to **B**)

Important Notes :

- a. After draw polyline connecting the points, use properties manager to change polyline Z value = 0
- b. Only work with 2D Polyline (Elevation , SS Width, ES Width & G Width = 0.000)
- c. Set Point Style to "Circle Cross" (Refer to below)

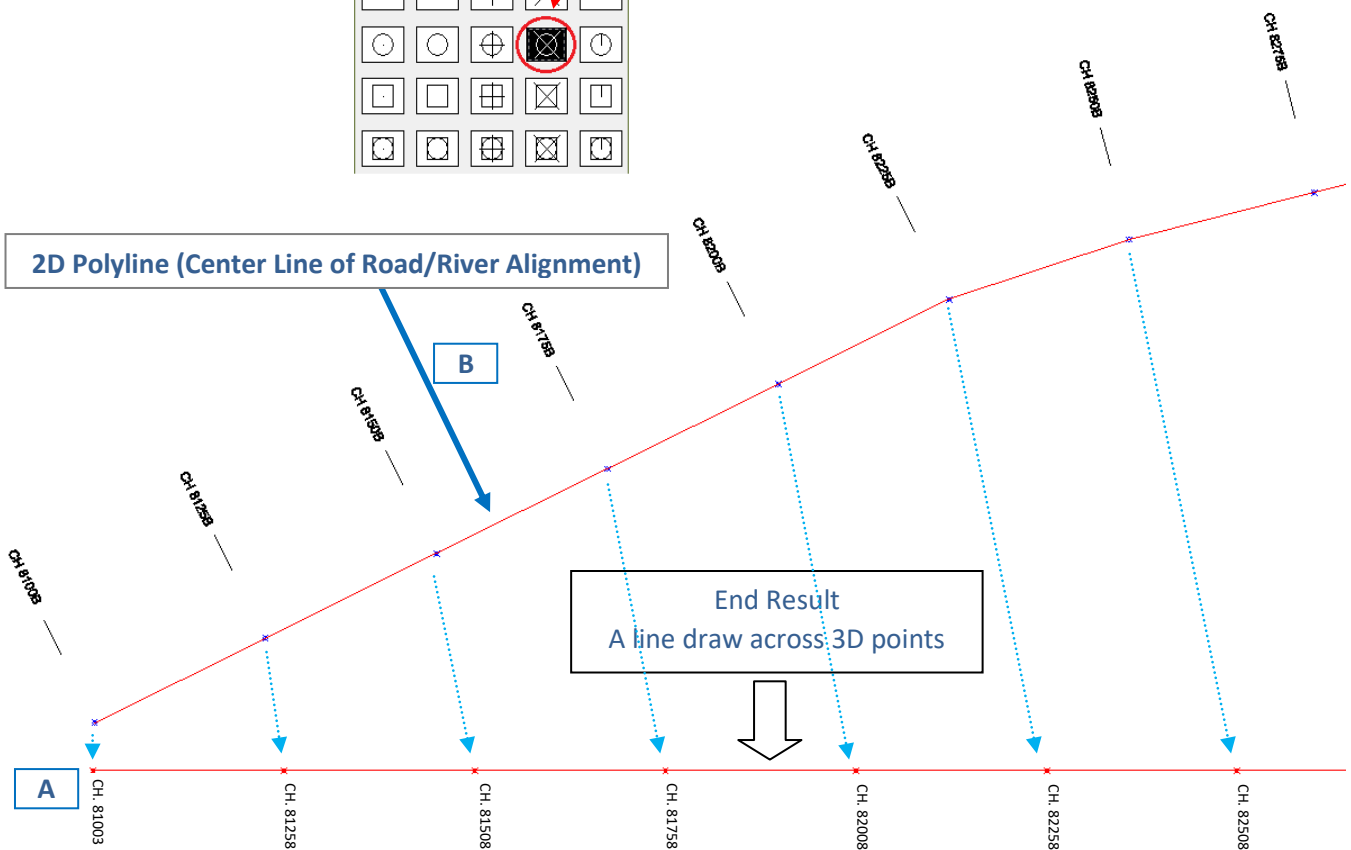
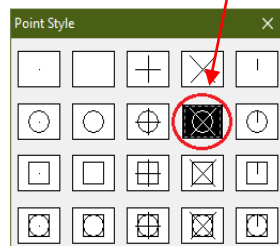
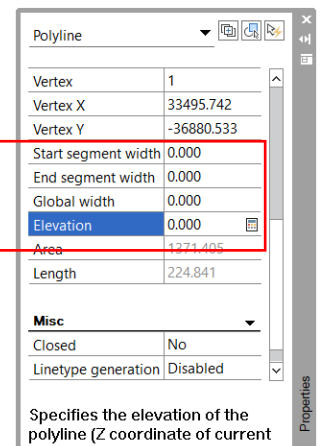

Function 28: Text In box

Function description: To add box on the text.

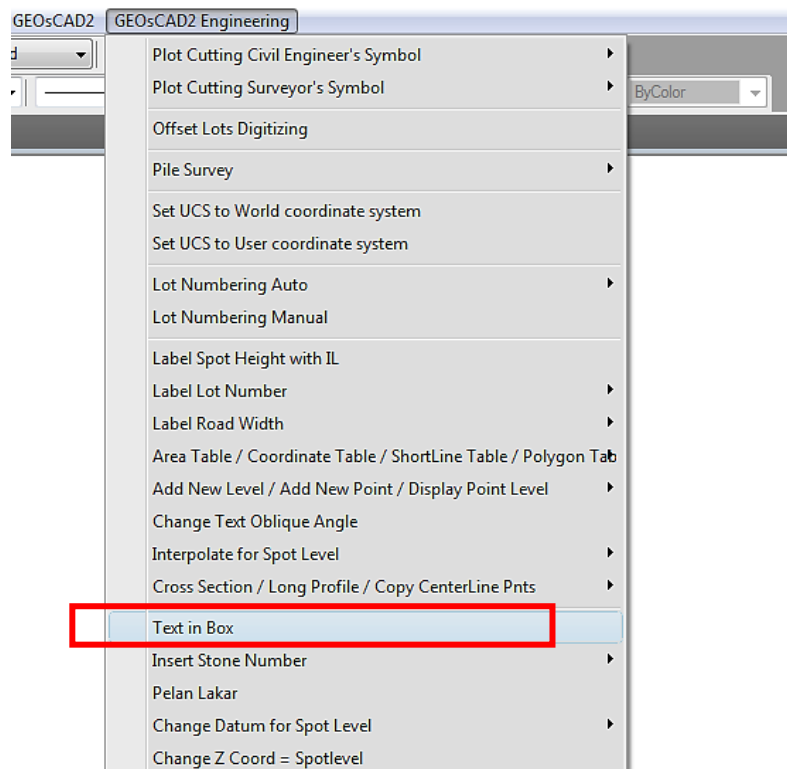

(Figure 28)

1. From GeoSCAD2 Engineering menu, choose **[Text in Box]** (Refer *Figure 28*).
2. Picking points that need box and then click enter.
3. Repeat step to continue and press Esc to cancel.
4. Example :

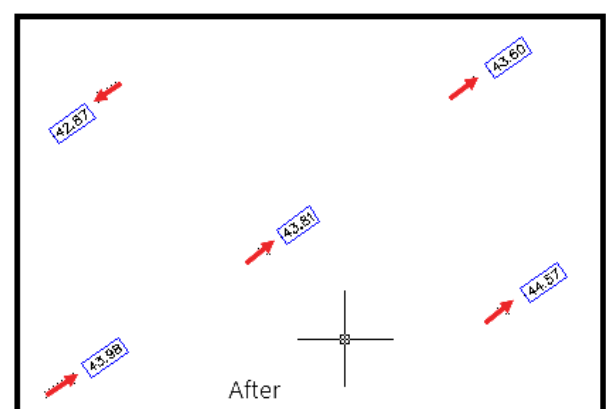
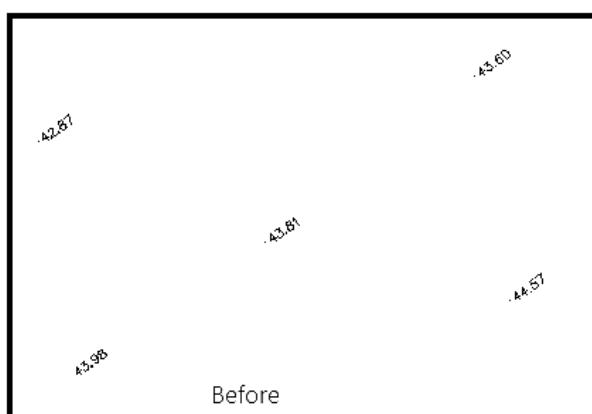

Example

Function 29: Insert Stone Number

Function description: To enter the stone number in drawing.

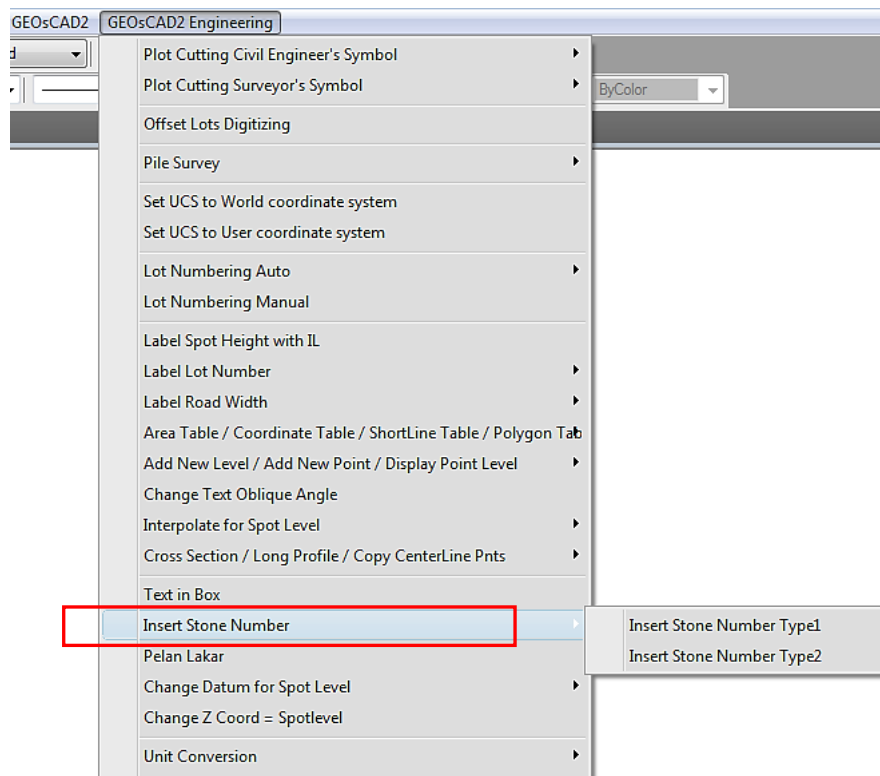

(Figure 29)

1. From GeoSCAD2 Engineering menu, choose Insert **[Stone Number]** (Refer *Figure 29*).
2. Select a BKL display point (pick point).
3. Enter Top Stone Number (e.g. 142) and enter Bottom Stone Number (e.g. 111), and then Esc to cancel.
4. Repeat step if require.
5. Example :

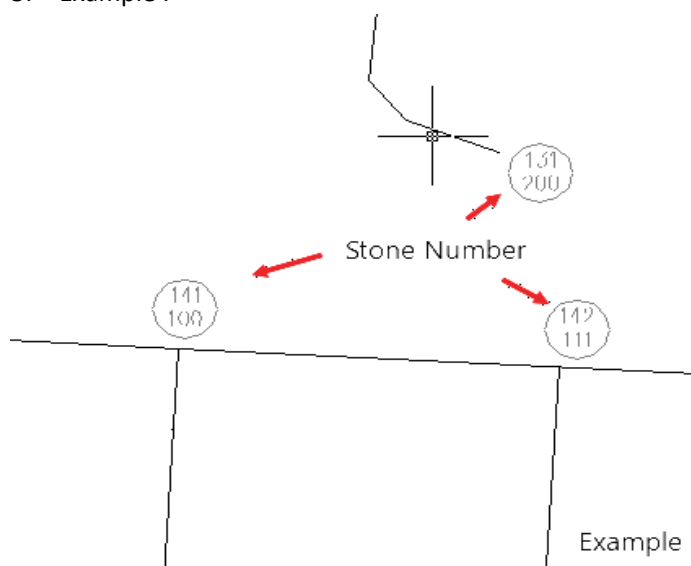

Function 30: Pelan Lakar

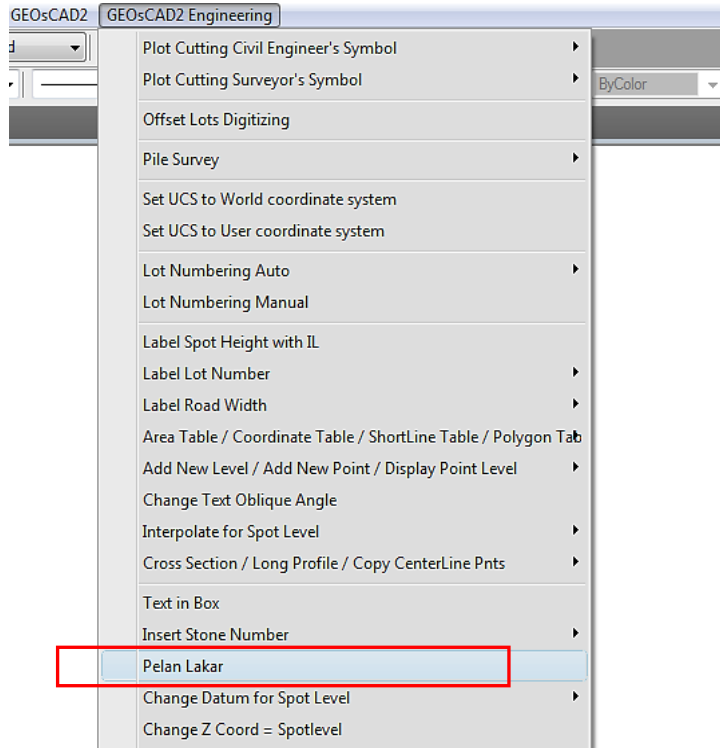

(Figure 30)

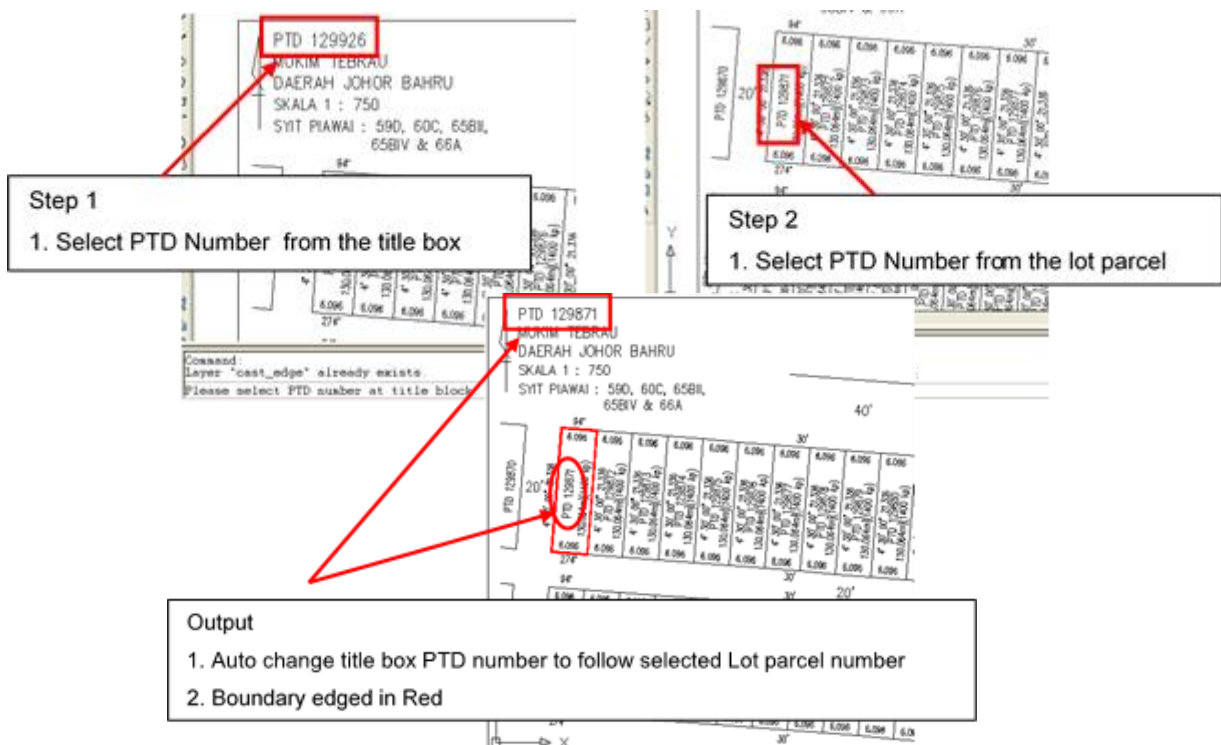

Function 31: Change Datum for Spot Level

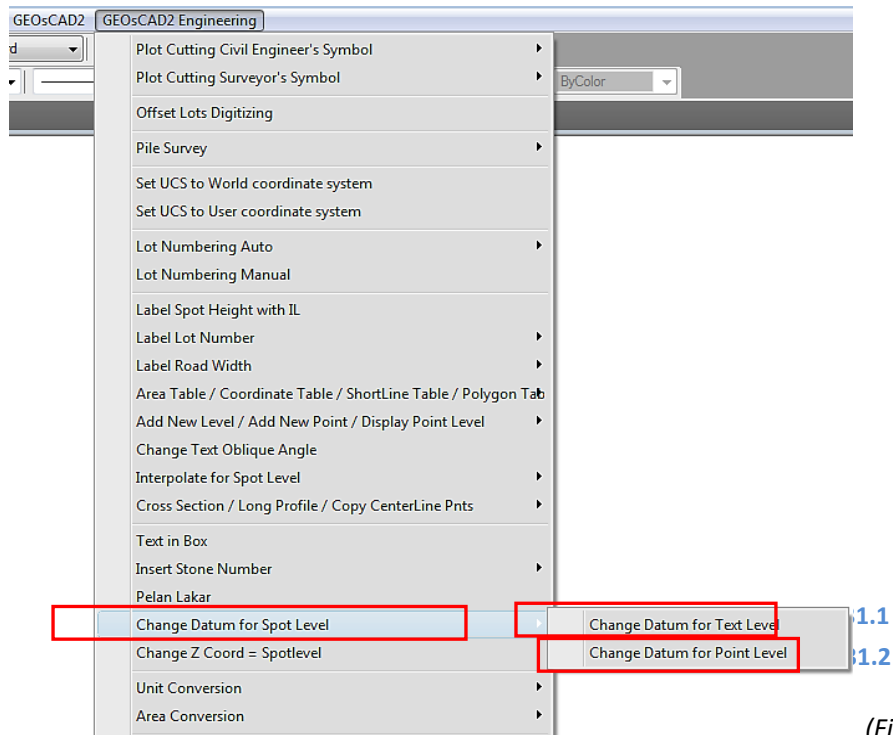

(Figure 31)

31.1 Change Datum for Text Level

Function Description: To change the text value of spot level

1. From GeoSCAD2 Engineering menu, choose ➤ **Change Datum for Text Level**
2. Enter a new datum to add to text (as shown in illustration below)

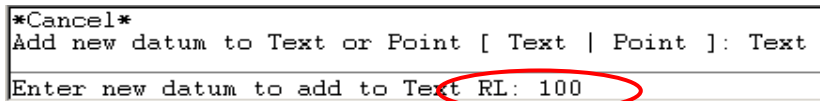

3. Select objects (you can use any selection method) and then right click mouse button to complete the command. (See illustrations below)

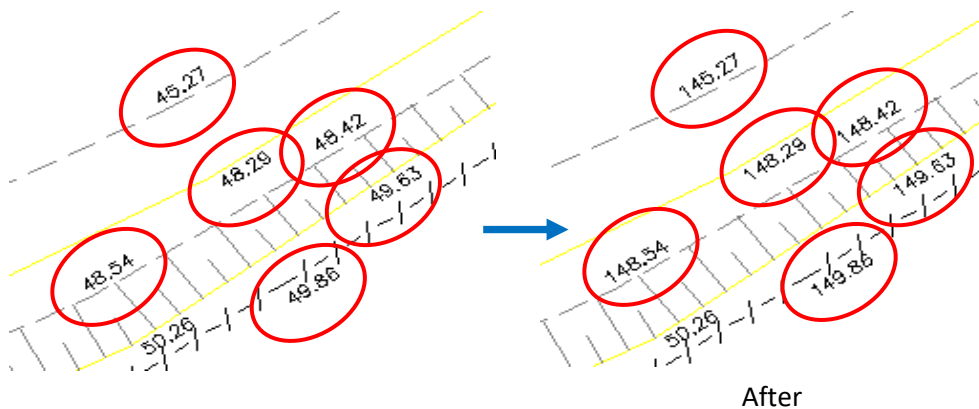

4. Repeat step 2 to 3 to continue.

31.2 Change Datum for Point Level

Function Description: To change the point value of spot level

1. From GeoSCAD2 Engineering menu, choose ➤ Change Datum for Point Level. (Refer Figure 31)
2. Enter a new datum to add to point (as shown in illustration below) (eg. enter '100')

```
*Cancel*
Add new datum to Text or Point [ Text | Point ]: Point
Enter new datum to add to Point RL:
```

3. **Select objects** (you can use any selection method) and then right click mouse button to complete the command. (See illustrations below)

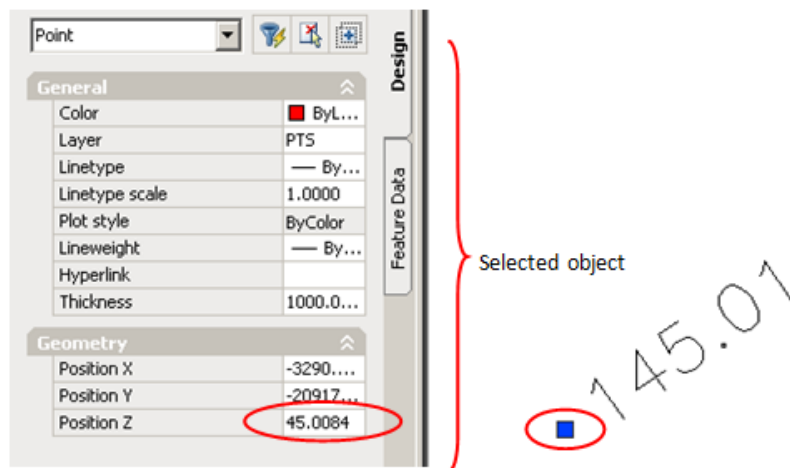

The properties for position z are 45.01 (the value before make any

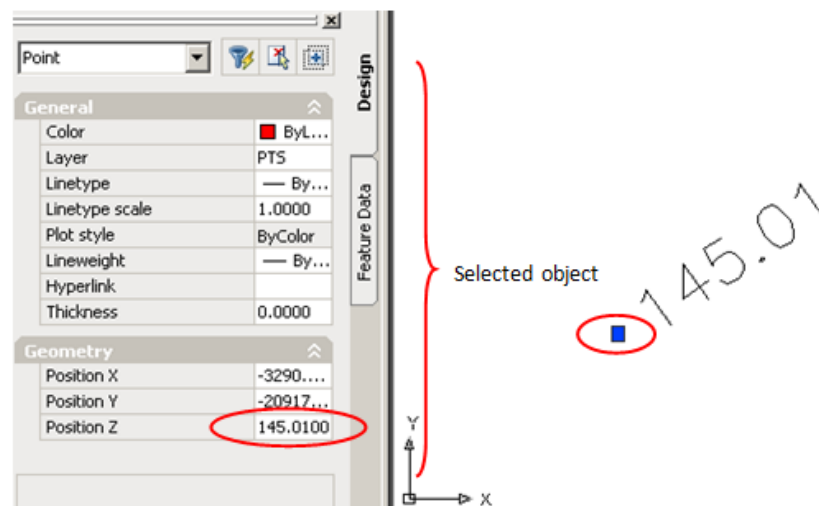

The properties for position z change to 145.01 (the value after add 100 to

4. Repeat step 2 to 3 to continue.

Function 32: Change Z Coord = Spot level

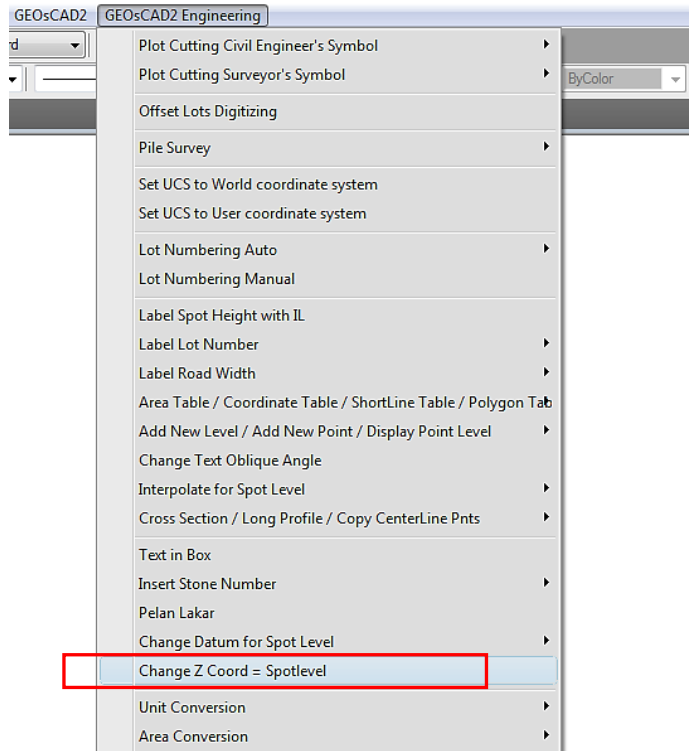

(Figure 32)

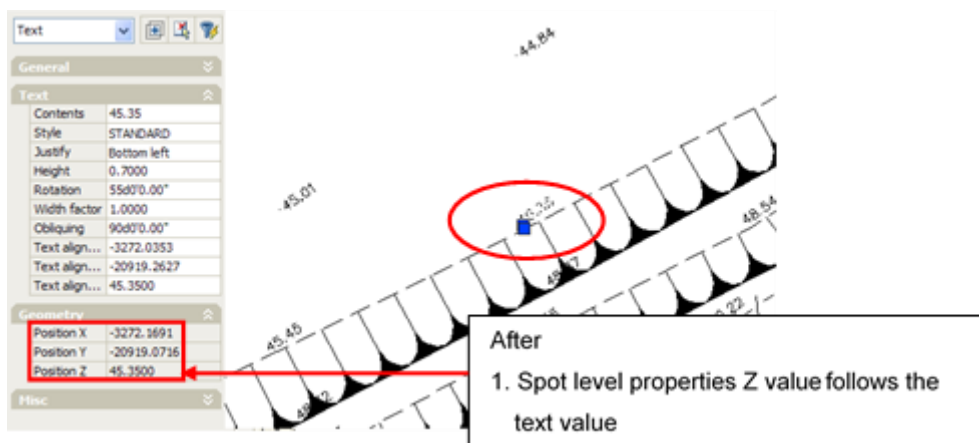
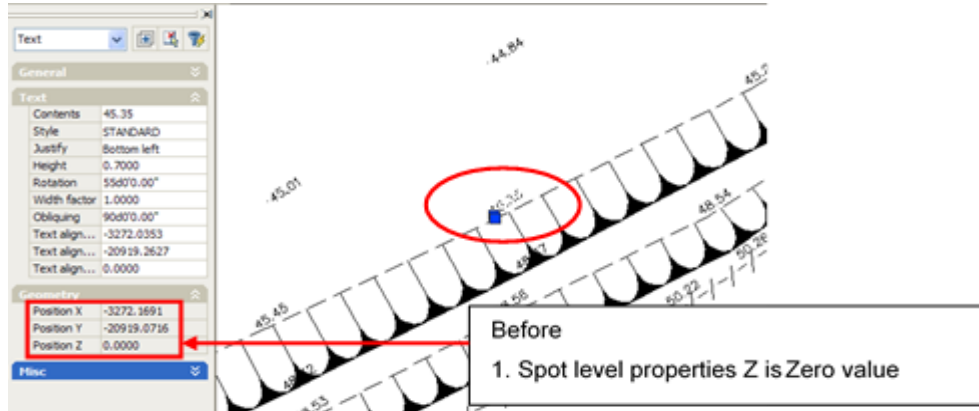

Function 33: Conversion

33.1 Unit Conversion for Distance or Levels

Function Description: To convert Text (Spot Level/Point Height Distance) base on conversion table.

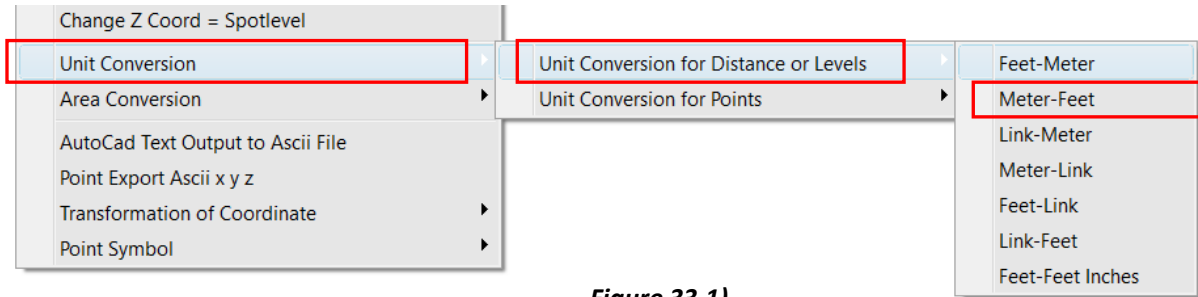
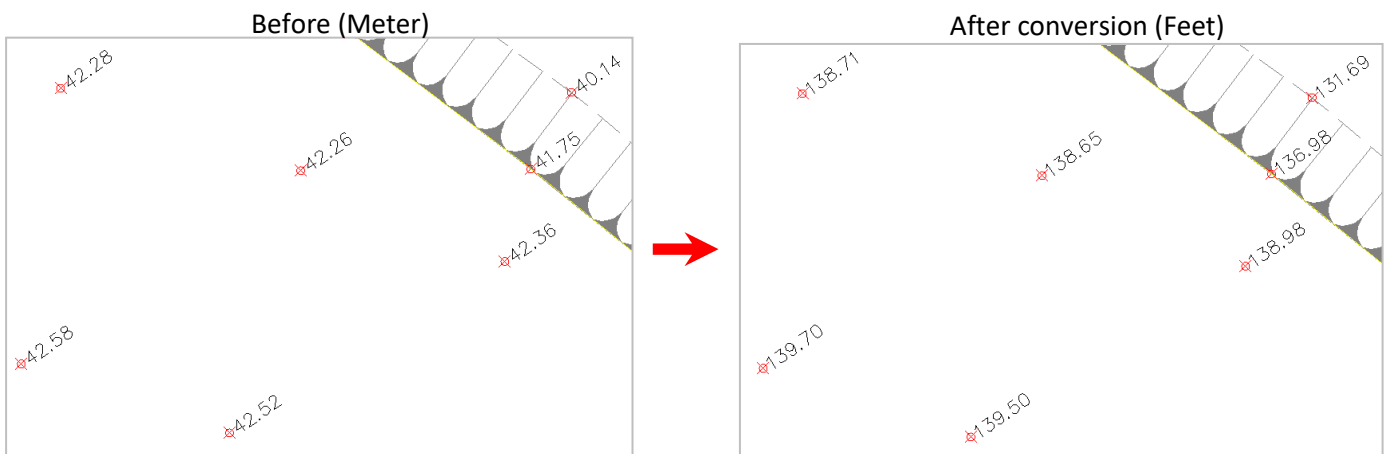

Figure 33.1)

1. From GeoSCAD2 Engineering menu, choose ➤ *Unit Conversion For Distance or Levels* ➤ **Meter-Feet**
 Level conversion units [Feet-Meter = 1 | Meter-Feet = 2 | Link-Meter = 3 | Meter-Link = 4 | Feet-Link = 5 | Link-Feet = 6 | Feet-Feet Inches = 7]: 2
2. Please enter new decimal value <2> : **2**
3. Select objects (**Spot Level's Text**)



33.2 Unit Conversion for Points Level

1. From GeoSCAD2 Engineering menu, choose ➤
Unit Conversion For Points ➤ **Meter-Feet**
2. Please enter new decimal value <2> : **2**
3. Select objects (**Points Symbols**)

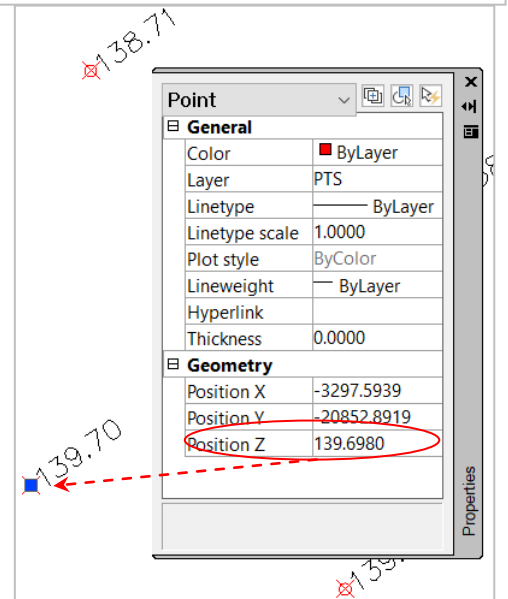

33.3 Area Conversion

Function Description: To convert Area's Text base on conversion table.

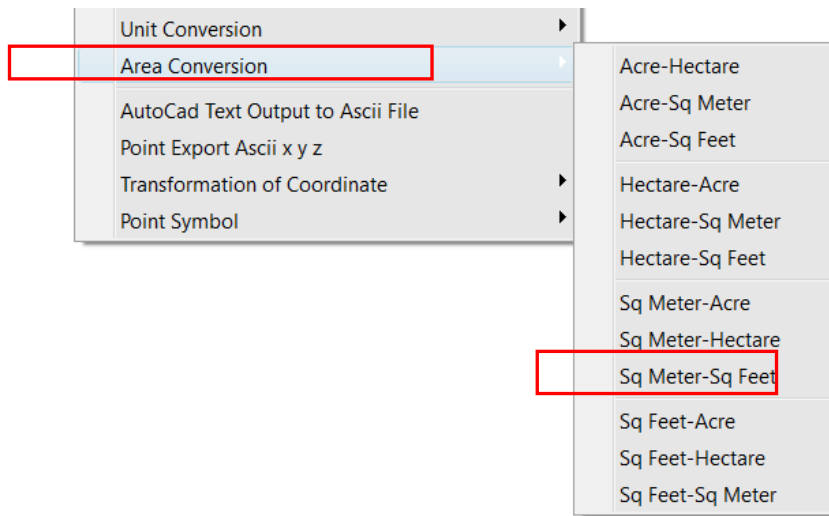

(Figure 33.3)

1. From GeoSCAD2 Engineering menu, choose ➤ *Area Conversion* ➤ **Sq Metres-Sq-Feet**
2. Please enter new decimal value <0> : **0**
3. Select objects (**Area's Text**)

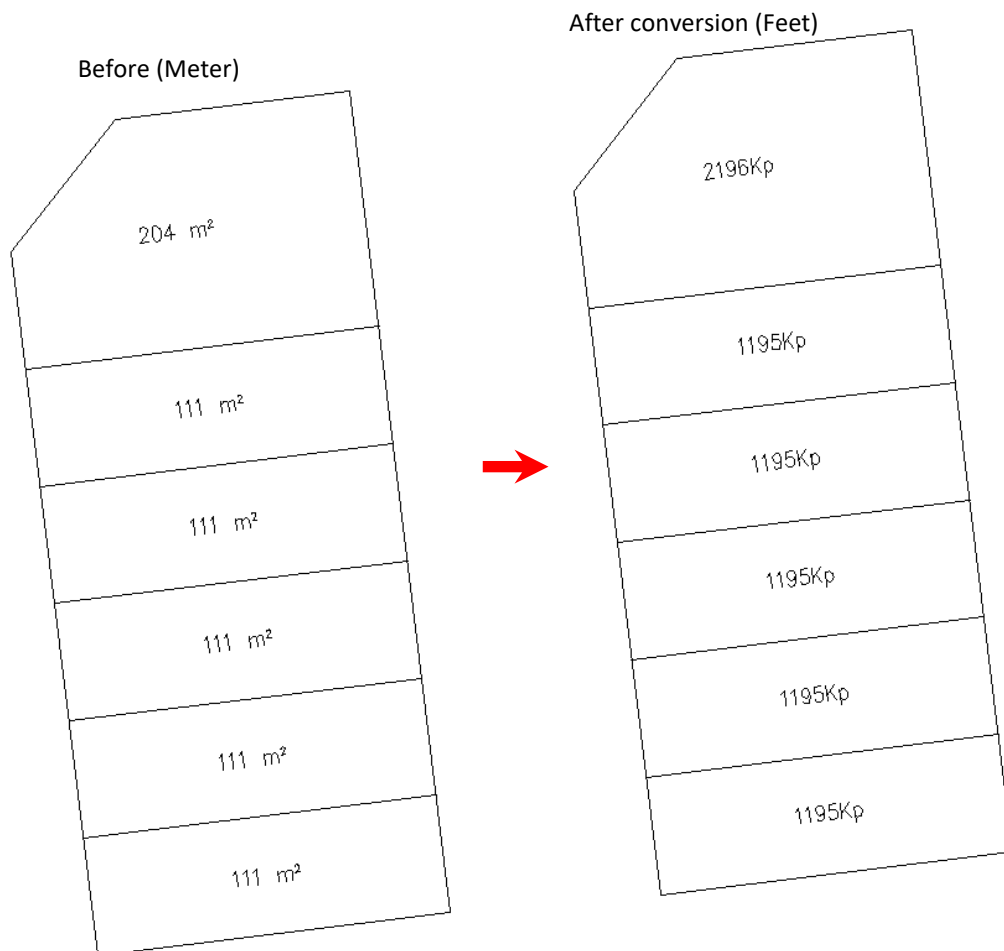

Function 34: AutoCad Text Output to Ascii File

Function description: To export Text (Lot Number) to ASCII file (C:\geoscad2\text.txt)

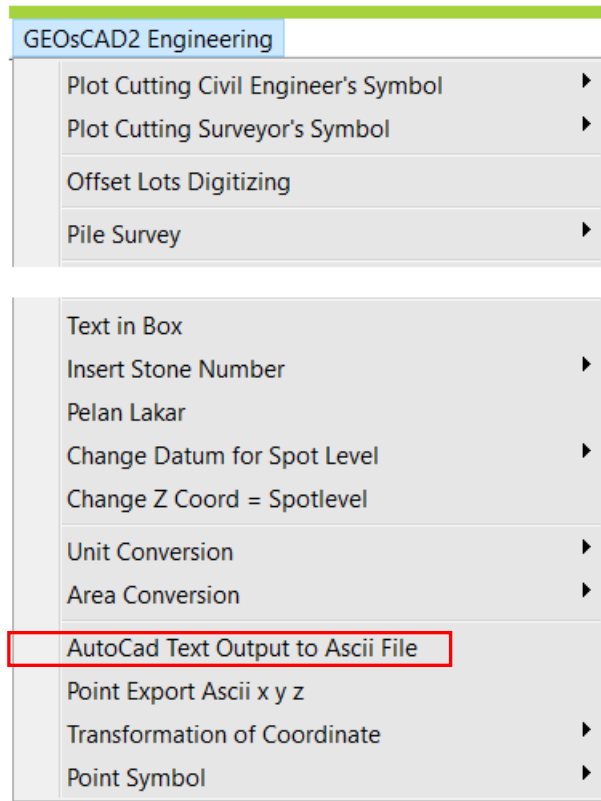

(Figure 34)

1. From GeoSCAD2 Engineering Menu ➤ **AutoCad Text Output to Ascii File** (Refer Figure 34).
2. Select objects: (Text object) follow by enter.
Note: Export Text Ascii file to Drive C:\geoscad2\out_txt.txt

Sample Drawing with Lot Number



C:\geoscad2\out_txt.txt

Text	X	Y	Rotation Angle
"3305"	16823.966323433284	-515.850797063980	276.955556000000
"3304"	16823.212030250255	-509.801621919878	276.955556000000
"3303"	16822.489879708308	-503.748525462047	276.955556000000
"3302"	16821.751657845813	-497.697389661079	276.955556000000
"3301"	16821.158077868193	-491.628607948330	276.955556000000
"3300"	16820.511216769679	-482.495727972415	276.955556000000

Function 35: Point Import Ascii x y z

Function description: To Import X,Y,Z Point from ASCII file into ZWCAD

1. From GeoSCAD2 Engineering Menu ➤ **Ascii Comma Delimited Import xyz**
2. Please enter new decimal value for spot height: **3**
3. Browse and select import file (ie. Pntxyz.txt)

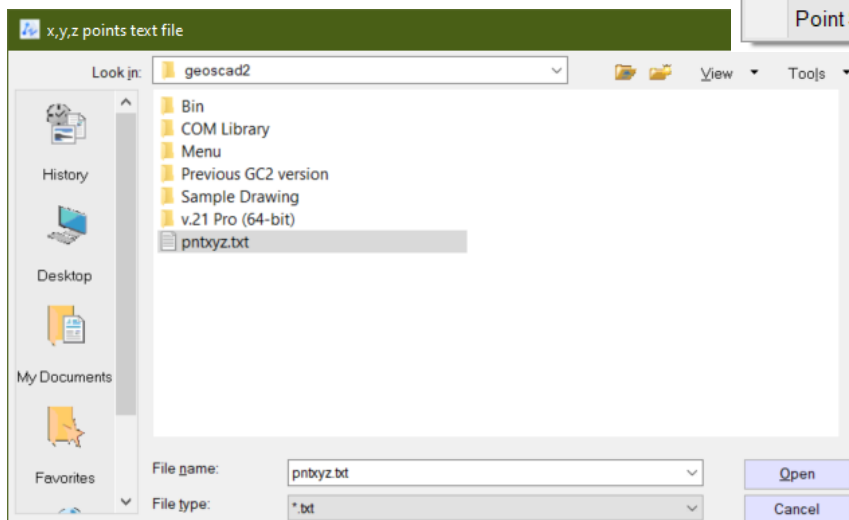
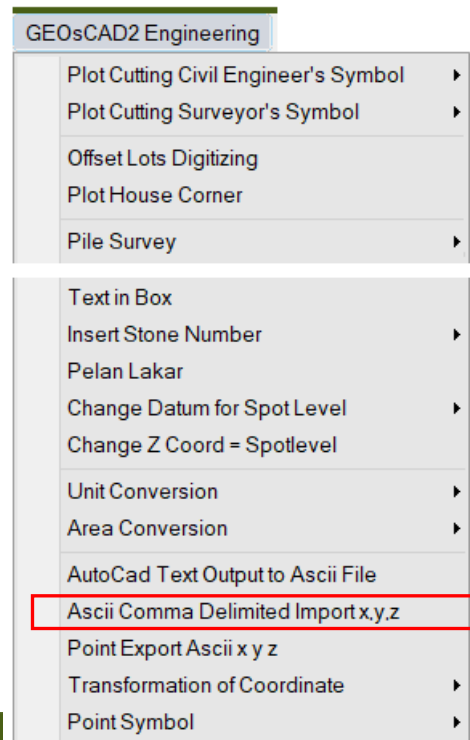

Function 36: Point Export Ascii x y z

Function description: To export Point to ASCII file (C:\geoscad2\text.txt)

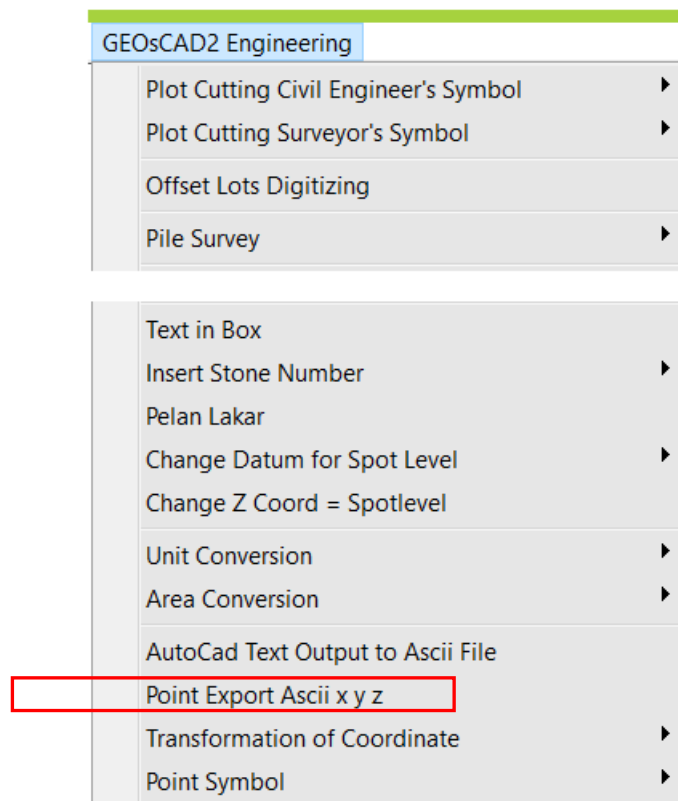

1. From GeoSCAD2 Engineering Menu ➤ **Point Export Ascii xyz**
2. Select objects: (Points object) follow by enter.
Note: Export Text Ascii file to Drive C:\geoscad2\ pntxyz.txt

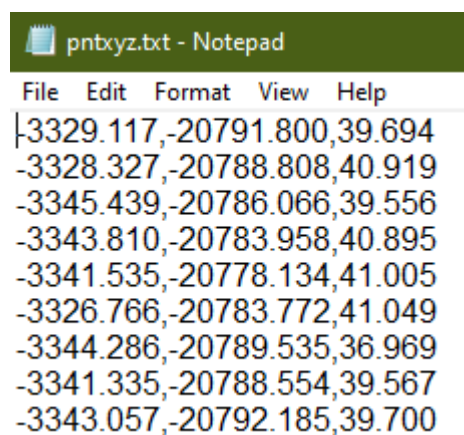

Function 37: Point Symbol

Function description: Insert point symbols

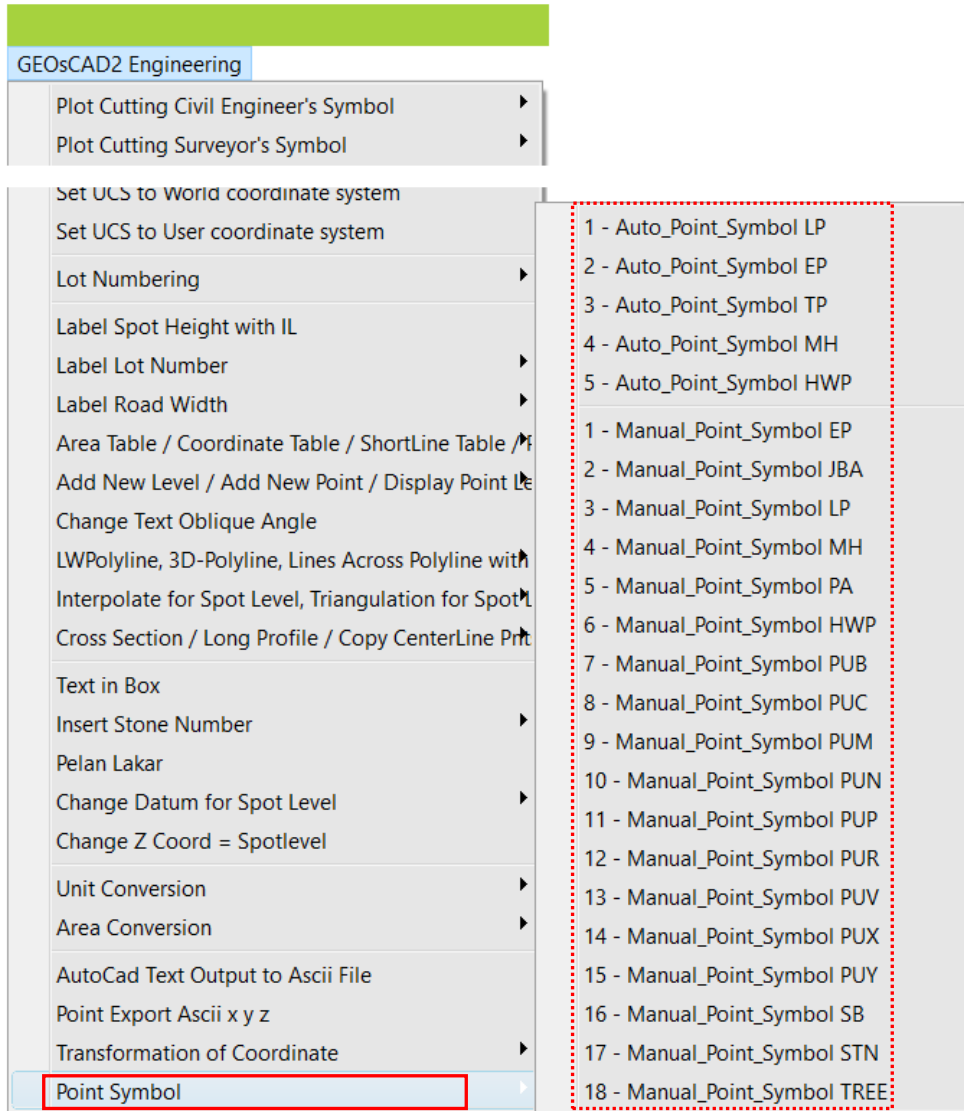

(Figure 37)

1. From GeoSCAD2 Engineering Menu, select **Point Symbol** ➤ choose the symbol wish to insert (refer to above figure 37 and next page figure 37.1 for reference)
2. Select objects and then right click mouse button or press Enter to insert symbol
3. Repeat step 2 to continue or press Esc to cancel

Notes:

- a) **Auto_Point_Symbol** (all types): Symbol Automatically generated by selecting points object.
- b) **Manual_Point_Symbol** (all types): Symbol generated by selecting a point object or pick on any selected insertion point.

Point Symbols (Auto)		Point Symbols (Manual)	
1.Auto_Point_Symbol LP		1.Manual_Point_Symbol EP	
2.Auto_Point_Symbol EP		2.Manual_Point_Symbol JBA	
3.Auto_Point_Symbol TP		3.Manual_Point_Symbol LP	
4.Auto_Point_Symbol MH		4.Manual_Point_Symbol MH	
5.Auto_Point_Symbol HWP		5.Manual_Point_Symbol PA	
		6.Manual_Point_Symbol HWP	
		7.Manual_Point_Symbol PUB	
		8.Manual_Point_Symbol PUC	
		9.Manual_Point_Symbol PUM	
		10.Manual_Point_Symbol PUN	
		11.Manual_Point_Symbol PUP	
		12.Manual_Point_Symbol PUR	
		13.Manual_Point_Symbol PUV	
		14.Manual_Point_Symbol PUX	
		15.Manual_Point_Symbol PUY	
		16.Manual_Point_Symbol SB	
		17.Manual_Point_Symbol STN	
		18.Manual_Point_Symbol TREE	

(Figure 37.1)

Some of the Symbol descriptions:

- LP: Lamp Post
- EP: Electric Post
- TP: Telephone Post
- MH: Manhole
- HWP: Hard Wood Peg
- JBA: Jabatan Bekalan Air
- PA: Traffic Lights Controller Box
- PUC: Telekom Manhole
- PUX: Transmission Pole

Function 38: Transformation of Coordinate

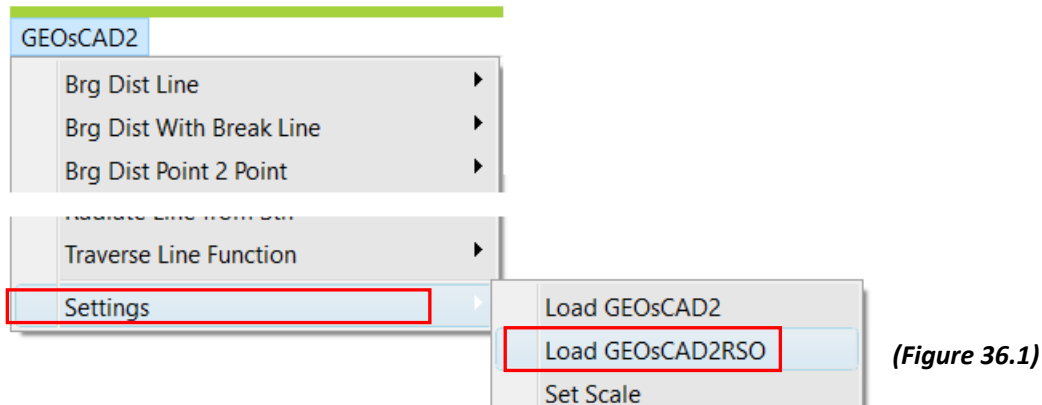

1. From GeoSCAD2 Menu, select **Settings** > **Load GEOsCAD2RSO** (refer to Figure 36.1). After successfully load proceed to step 2.

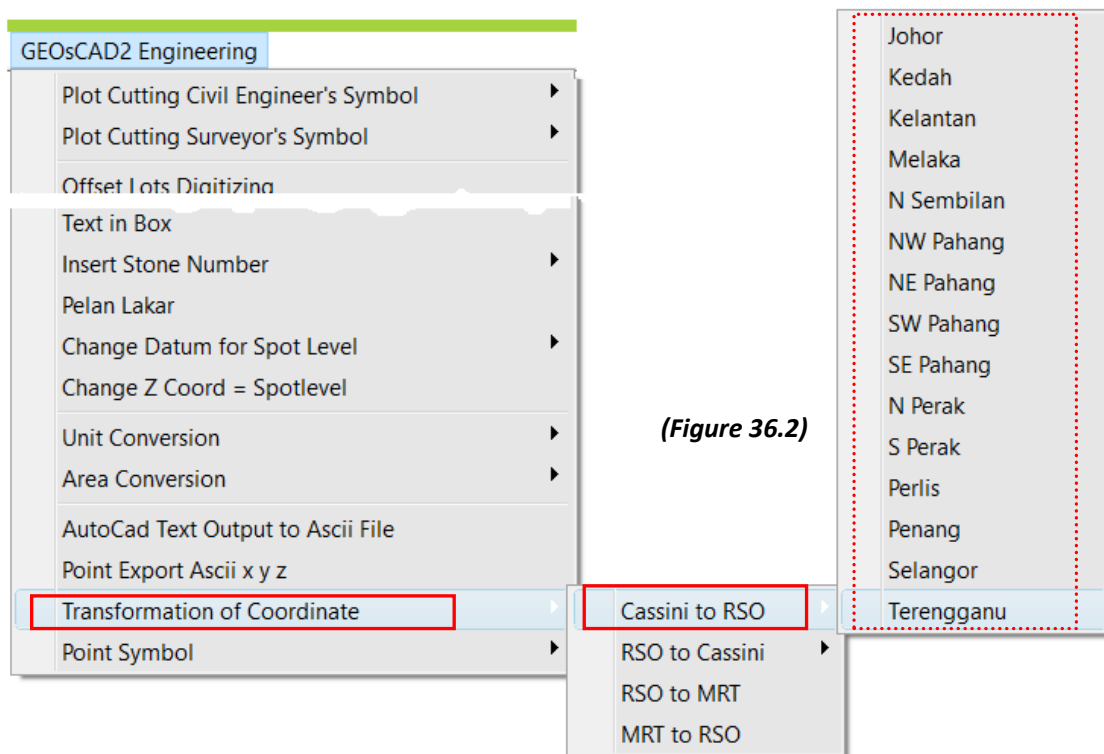

38.1 Cassini to RSO

38.2 RSO to Cassini

38.3 RSO to MRT

38.4 MRT to RSO

2. From GeoSCAD2 Engineering Menu, select **Transformation of Coordinates** > *select type of coordinates transformation and States if only applicable.* refer to above Figure 36.2)
3. Select all objects follow by return key to complete the transformation.
4. Zoom Extent and check object's coordinates.

